



**NANYANG
TECHNOLOGICAL
UNIVERSITY**

School of Mechanical & Aerospace Engineering

Design, Machine, Control, Intelligence

MA4829

Machine Intelligence

(AI 1.0 <><> AI 2.0 <><> AI 3.0)



XIE Ming, PhD (France)

<http://personal.ntu.edu.sg/mmxie>

“We are living inside an ocean of signals”



What is a system with intelligence inside?

(Learning, Teaching) <o> (Research, Innovation) <o> (Leadership, Service)

Outline of AI 3.0

- Module 1: True Foundation of Visual Intelligence
- Module 2: Visual Knowledge Representation
- Module 3: Visual Knowledge Perception
- Module 4: Visual Knowledge Computation
- Module 5: Visual Knowledge Applications

ABOUT NTU

Remember NTU's Vision ...



Remember NTU's Mission ...



Education

We deliver transformative educational experiences that make our students both future- and AI-ready, so they are sought after by employers.

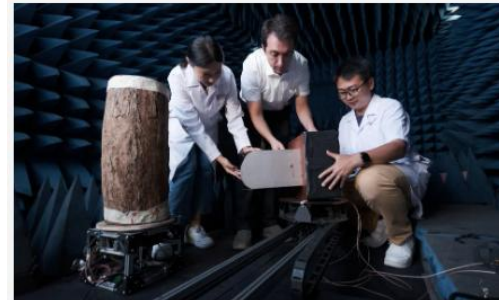

House of Talent

We attract, develop, and retain the very best people to drive excellence across the University.



Research, Innovation and Enterprise

We pursue breakthrough discoveries. We integrate technology and the humanities to address global challenges. We accelerate cutting edge innovation and create promising new enterprises.



Hub of Global Impact

We drive global impact in all that we do. We pursue long-lasting global partnerships with like-minded institutions across the world.

Education is to help citizens to fulfill their missions on Earth, which include: to understand the world and to improve the world ...



ABOUT YOU

Remember your mission as MAE undergraduates ...

- You are here to grow your knowledge and skills so as to be able to design machines with controllable behaviors and hopefully in some intelligent ways.

How to fulfill your mission?

- To apply learnt knowledge and skills into the implementation of the following universal blueprint underlying all the intelligent machines or systems.

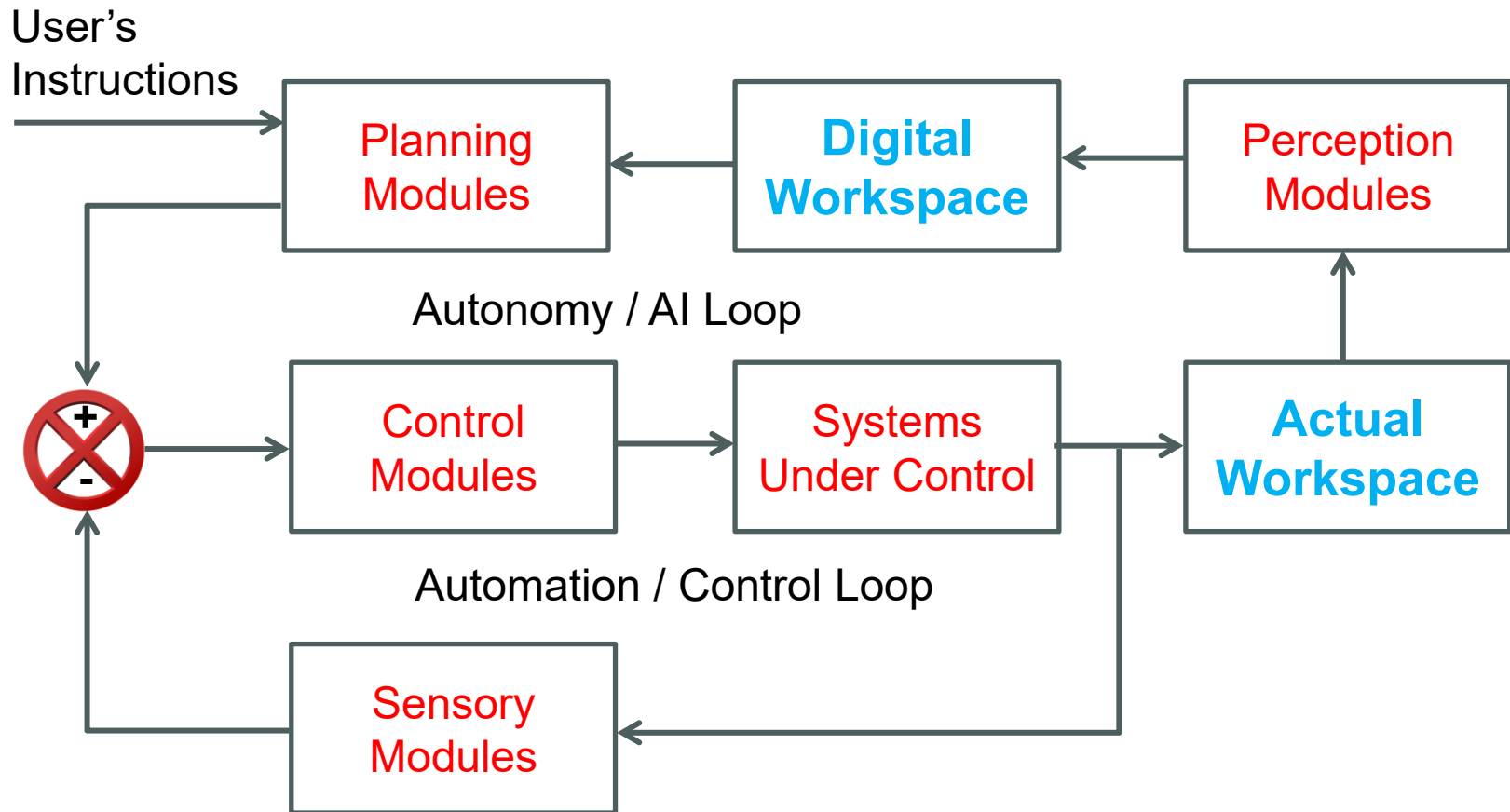

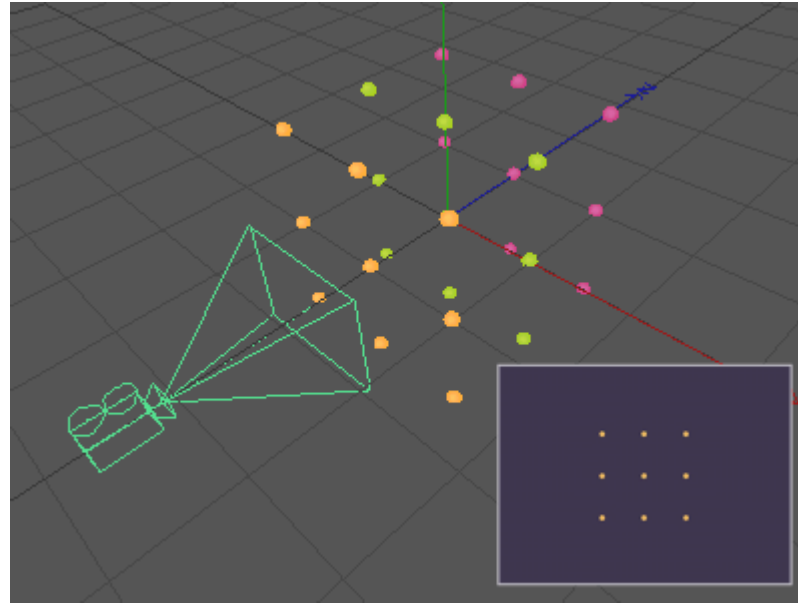

ABOUT COURSE

Two Big Questions ...

- How to achieve automation?
 - To apply the theory of control
- How to achieve autonomy?
 - To apply the theory of mind

Two Big Dilemmas ...

- Top-Down Design versus Bottom-Up Optimization
 - Should the creatures in the universe be the outcomes of designs by **Designers** or the outcomes of natural evolution by **Optimizers**?

- Mind-Centric Approach versus Brain-Centric Approach
 - Does intelligence arise from **Mind** or from **Brain**?

Dilemma versus Common Sense ...

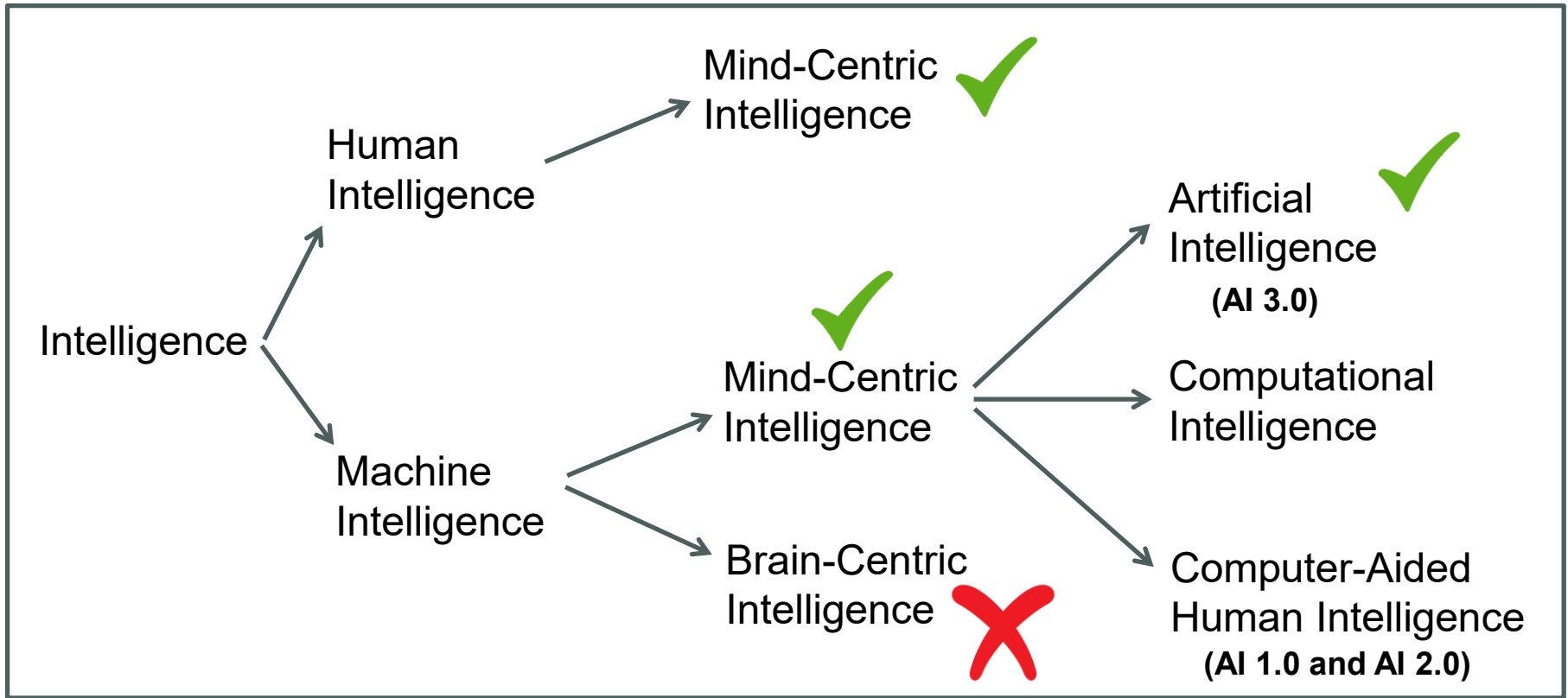

Why to study visual intelligence?

“We are living inside an ocean of signals”

- The motivation is to achieve machine’s self-intelligence.

- More specifically, we aim at achieving the transformations from visual signals to cognitive states of knowing the meanings inside the visual signals.

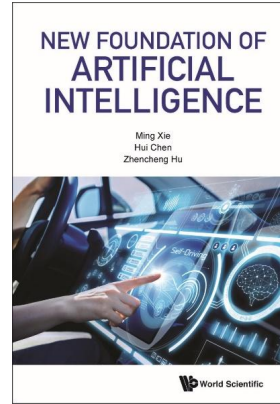
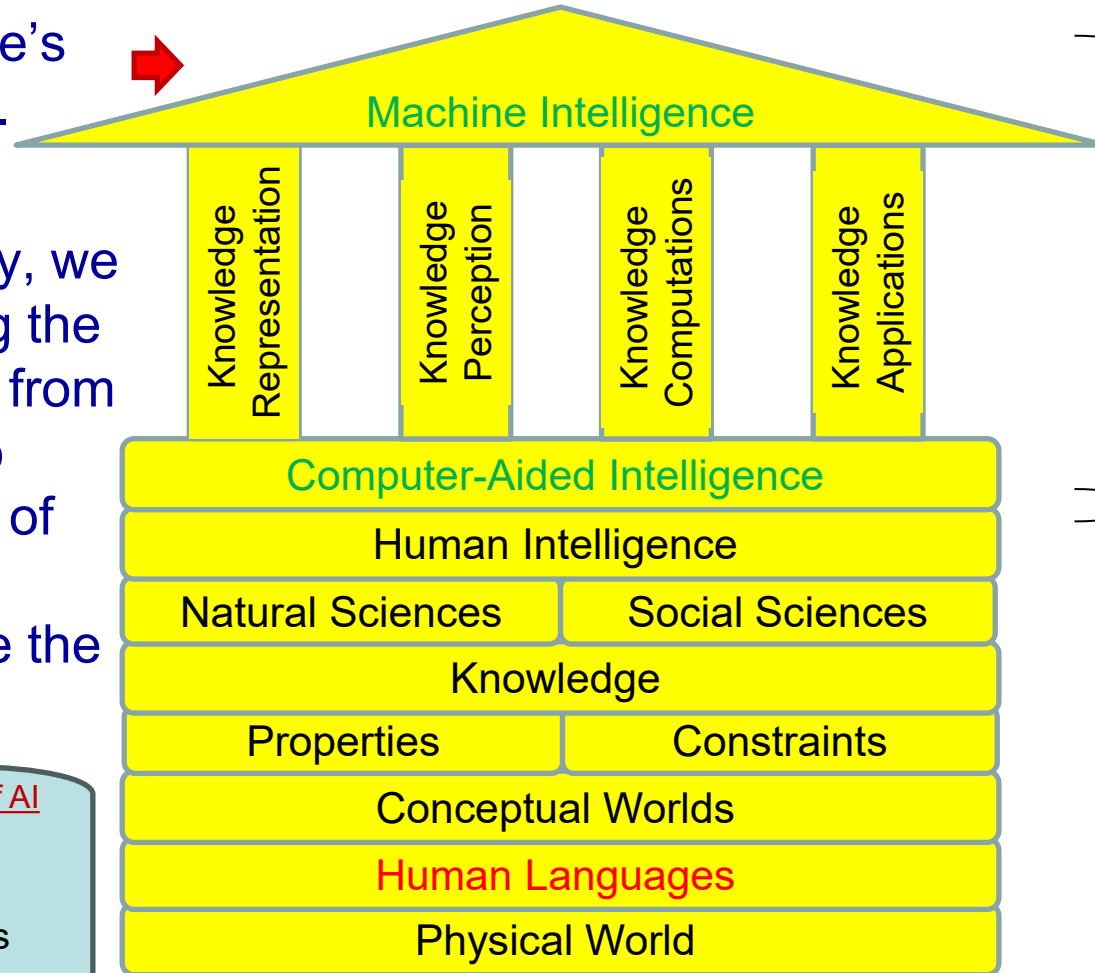

Artificial Intelligence

Human Intelligence

- Keys of AI
- One Tool
 - Two Worlds
 - Three Intelligences
 - Four Pillars

Copyright @ Ming Xie

What to learn?

Roadmap of Visual Intelligence

True Foundation of AI

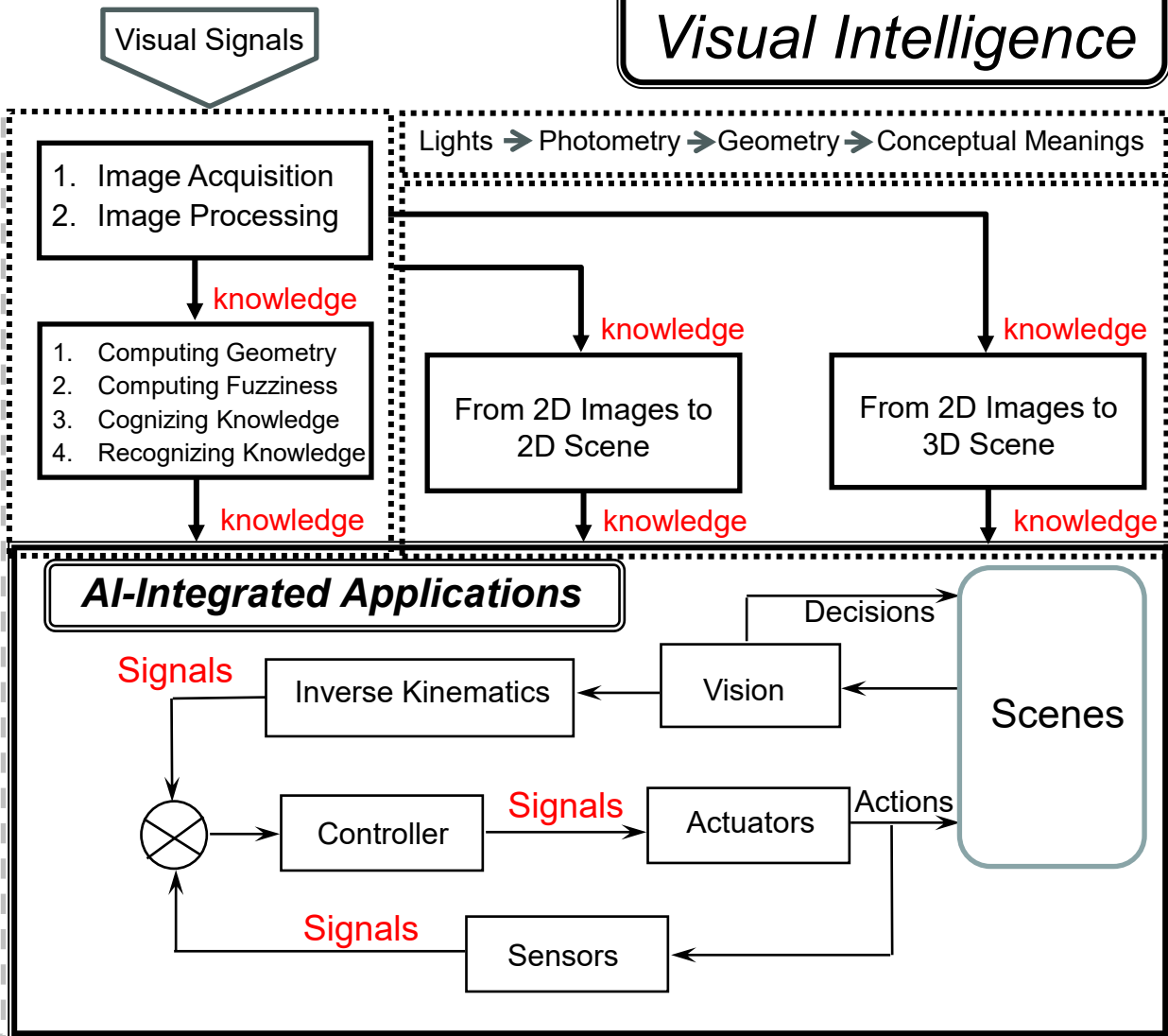
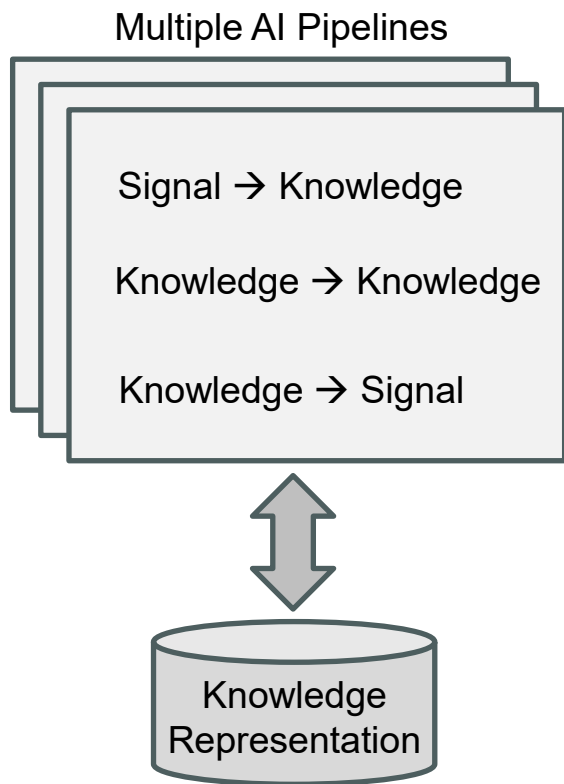

How to study visual intelligence?

- To put yourselves into the mindset of designers of intelligent systems:
 - Who are the users? (**any machine with intelligence inside**)
 - What are the needs of users? (**to transform visual signals into knowledge**)
 - What are your intelligent systems? (**to spell out the functionality**)
 - What are the solutions behind the design of your intelligent systems?

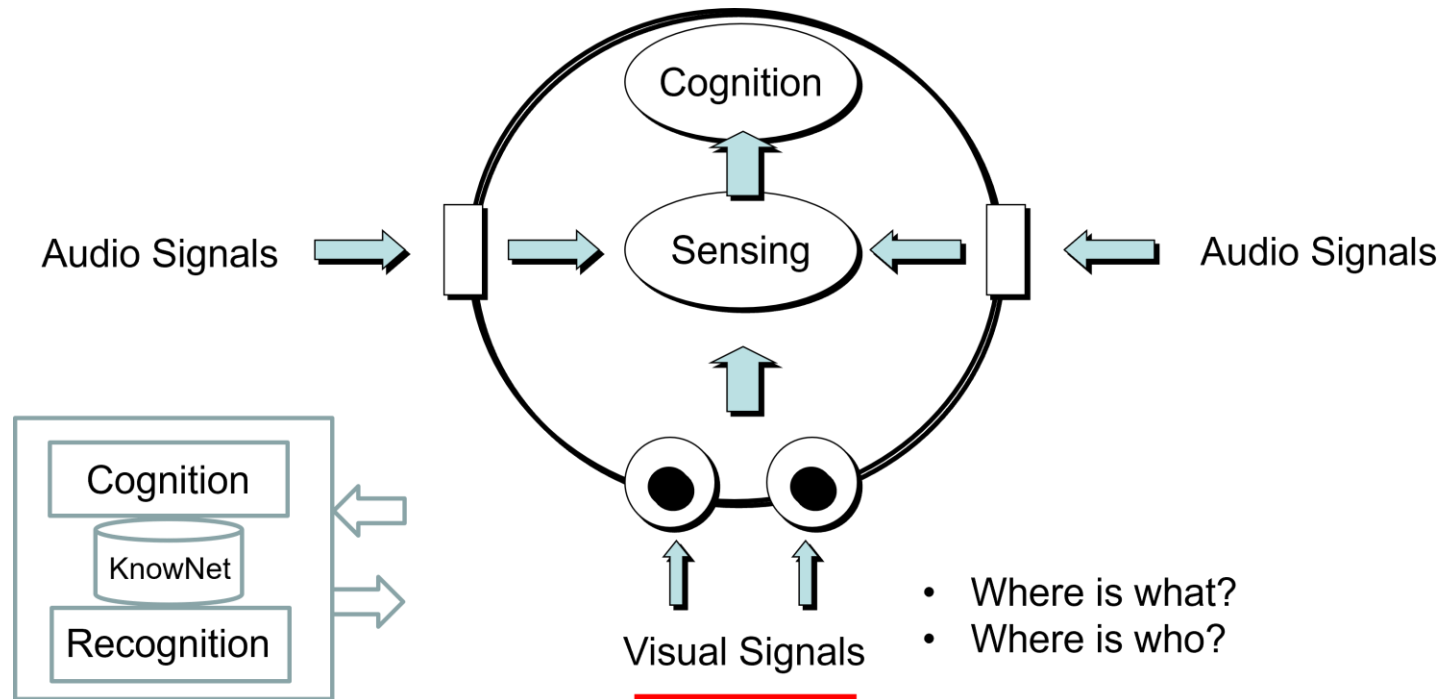

How to apply?

- You could use MATLAB to quickly apply:
 - What you have read
 - What you have heard
 - What you have learnt

Practice

Practice

Practice

MATLAB = No.1 AI Software
(Rapid Prototyping Software)



We are more affected by Beliefs than by Truths.

Should Seeing be Believing?

Should Seeing Be Believing?

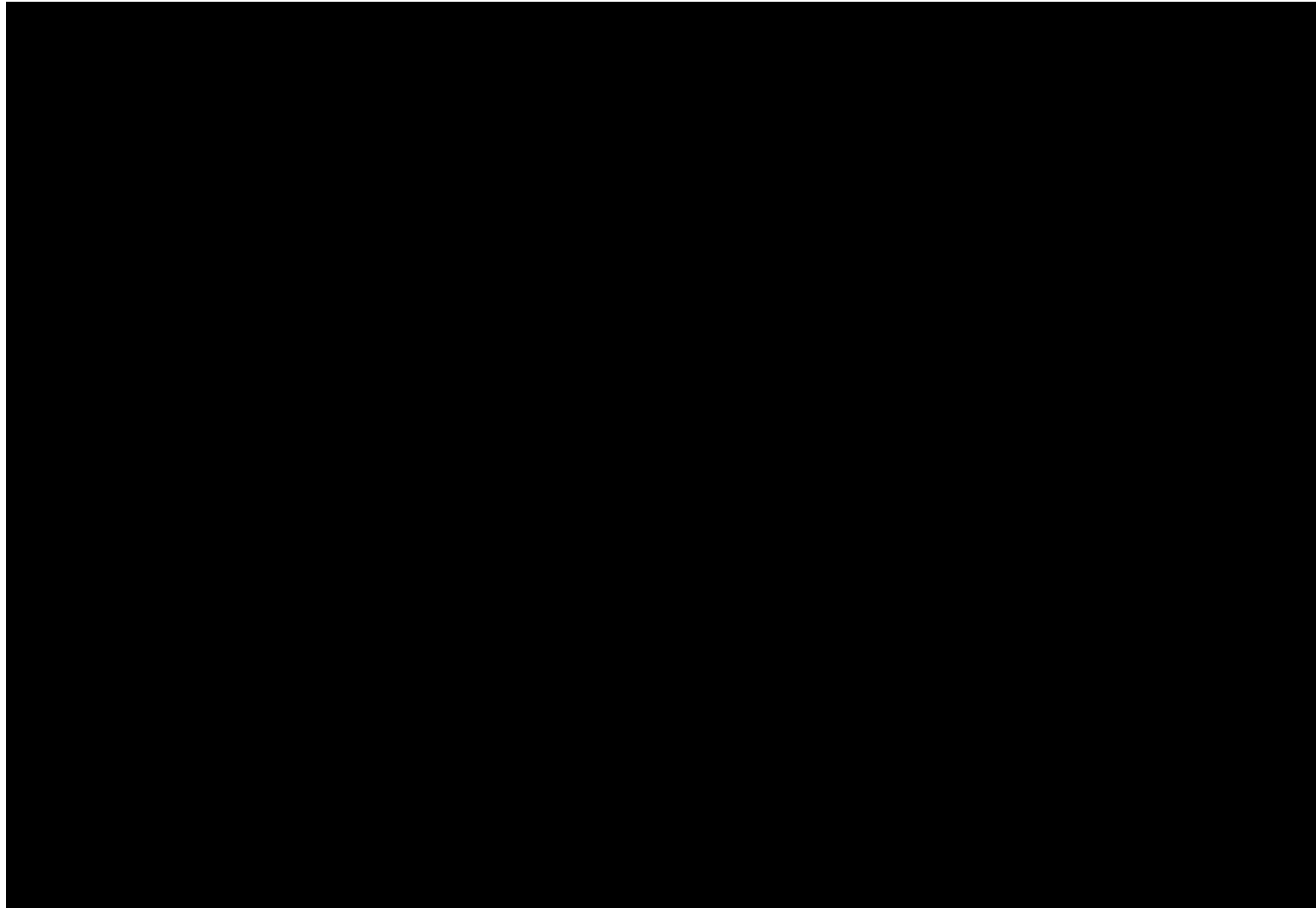

Terminology Alert ...

1. Image properties at the lowest level include **continuities** and **discontinuities**. Hence, there are two types of pixels which are **color pixels** and **edge pixels**. These are the **identities** of pixels at the lowest level.
2. Therefore, “how to transform pixels into their identities?” is the so-called problem of **symbol grounding** in visual intelligence.
3. As a result, **symbol groundings** include symbol grounding of color pixels and symbol grounding of edge pixels.
4. **Symbol grounding of color pixels** is a process of **sense-making** which transforms pixels into common-sense or inner-sense of colors.
5. **Symbol grounding of edge pixels** is also a process of **sense-making** which transforms pixels into common-sense or inner sense of curves.
6. The combinations of colors and curves create meaningful **patterns**.

Today's Lectures ...

- **Module 1: True Foundation of Visual Intelligence**
- Module 2: Visual Knowledge Representation
- Module 3: Visual Knowledge Perception
- Module 4: Visual Knowledge Computation
- Module 5: Visual Knowledge Applications



**NANYANG
TECHNOLOGICAL
UNIVERSITY**

School of Mechanical & Aerospace Engineering

Design, Machine, Control, Intelligence

Module 1

AI 3.0

MA4829 Machine Intelligence

True Foundation of Visual Intelligence

XIE Ming, PhD (France)

<http://personal.ntu.edu.sg/mmxie>

“We are living inside an ocean of signals”



What is a system with intelligence inside?

(Learning, Teaching) <o> (Research, Innovation) <o> (Leadership, Service)

Outline of Module 1

- [Lecture 1](#):
 - True Foundation of AI Systems
- [Lecture 2](#):
 - Input to AI Systems
- [Lecture 3](#):
 - Output from AI Systems



Outline of Module 1

- Lecture 1:
 - True Foundation of AI Systems
- Lecture 2:
 - Input to AI Systems
- Lecture 3:
 - Output from AI Systems





**NANYANG
TECHNOLOGICAL
UNIVERSITY**

School of Mechanical & Aerospace Engineering

Design, Machine, Control, Intelligence

Lecture 1 of Module 1

AI 3.0

MA4829 Machine Intelligence

True Foundation of AI Systems



XIE Ming, PhD (France)

<http://personal.ntu.edu.sg/mmxie>

“We are living inside an ocean of signals”



What is a system with intelligence inside?

(Learning, Teaching) <o> (Research, Innovation) <o> (Leadership, Service)

Outline of Lecture 1

- AI 1.0: Machine Thinking
- AI 2.0: Machine Learning
- AI 3.0: Machine Self-Intelligence
- Overview of Machine's Visual Intelligence

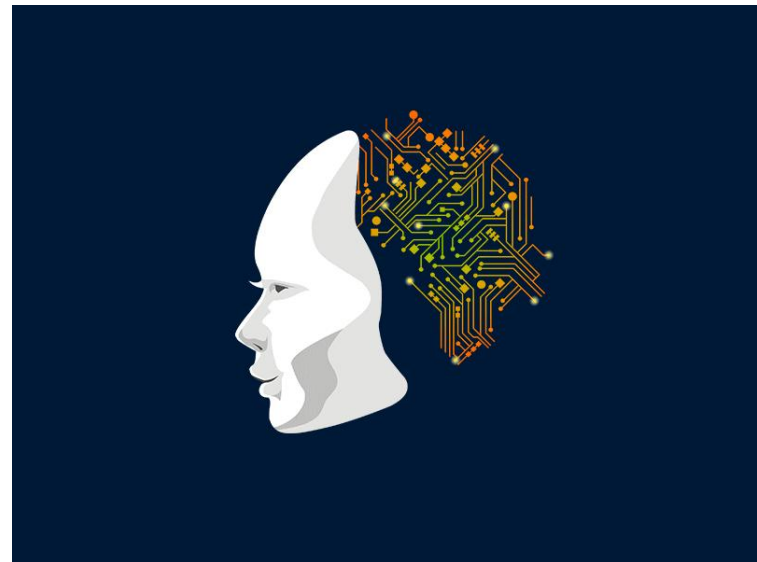

Outline of Lecture 1

- AI 1.0: Machine Thinking
- AI 2.0: Machine Learning
- AI 3.0: Machine Self-Intelligence
- Overview of Machine's Visual Intelligence

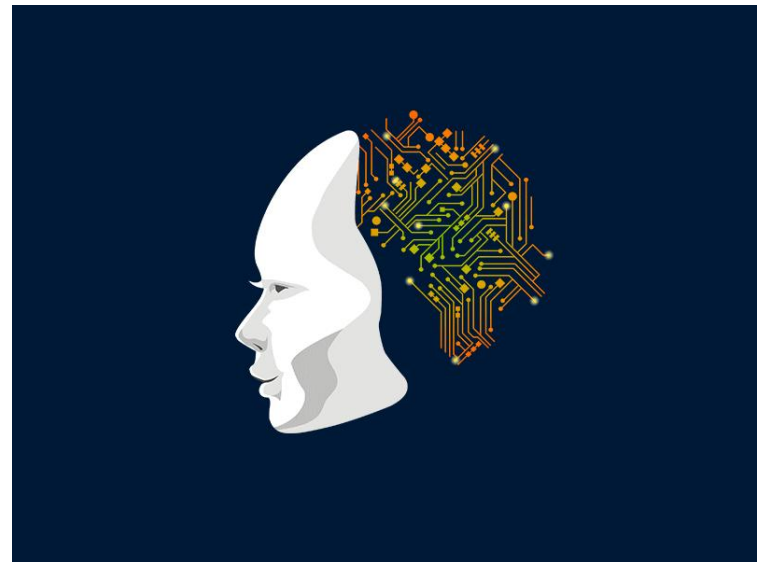

A Special Person ...

- Researchers in the United Kingdom had been exploring “Machine Intelligence” for up to ten years prior to the founding of the field of Artificial Intelligence ([AI](#)) research in 1956.
- Machine Intelligence was a common topic among the members of the [Ratio Club](#), an informal group of British [cybernetics](#) and [electronics](#) researchers that included Alan Turing.
- Alan Turing, in particular, had been running the notion of machine intelligence since at least 1941 and one of the earliest-known mentions of “Computer Intelligence” was made by him in 1947.



A Special Beginning of AI ...

History of AI

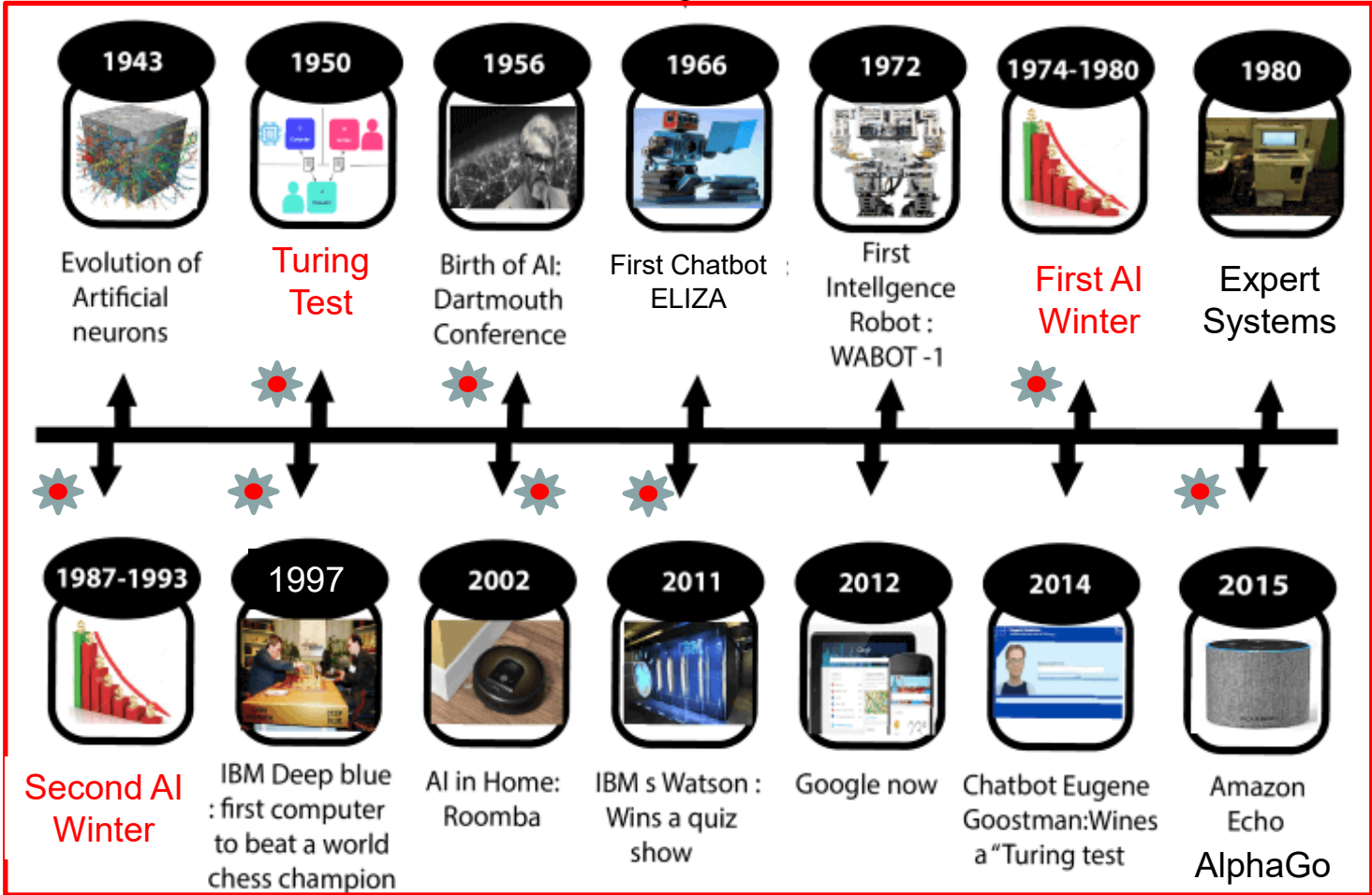

Big Question:
Does intelligence arise from brain or mind?

An Astonishing Hypothesis ...

- *The Astonishing Hypothesis* is a 1994 book by scientist [Francis Crick](#) about [consciousness](#). Crick, one of the co-discoverers of the molecular structure of [DNA](#), later became a theorist for [neurobiology](#) and the study of the [brain](#).
- *The Astonishing Hypothesis* is mostly concerned with **establishing a basis for scientific study of consciousness**.
- However, Crick places the study of consciousness within a larger social context. Human consciousness according to Crick is central to human existence and so scientists find themselves approaching topics traditionally left to [philosophy](#) and [religion](#).

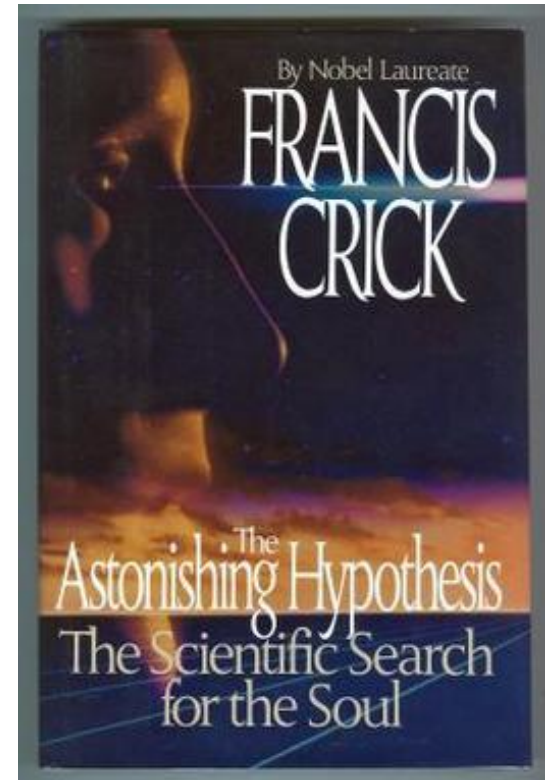

He made suggestion that by analyzing brain's signals, one should be able to discover the details of mind or soul.

AI 1.0

USA's Brain Initiative ...

- In April 2013, the President announced the launch of the BRAIN (Brain Research through Advancing Innovative Neurotechnologies) Initiative® – a bold, new initiative focused on revolutionizing our understanding of the human brain.
- The initiative will accelerate the development and application of new technologies that will enable researchers to produce dynamic pictures of the brain that show how individual brain cells and complex neural circuits interact at the speed of thought. These technologies will open new doors to explore how the brain records, processes, uses, stores, and retrieves vast quantities of information, and shed light on the complex links between brain function and behavior.

THE WHITE HOUSE IS ANNOUNCING
OVER \$300 MILLION IN PUBLIC AND PRIVATE INVESTMENTS
IN SUPPORT OF THE BRAIN INITIATIVE

the WHITE HOUSE
**BRAIN
INITIATIVE**

BRAIN RESEARCH THROUGH ADVANCING
INNOVATIVE NEUROTECHNOLOGIES

Since President Obama announced the **BRAIN Initiative** in April 2013, dozens of leading technology firms, academic institutions, scientists and other key contributors to the field of neuroscience have answered his call and made significant commitments to advancing the Initiative.

[VIEW THE FULL INFOGRAPHIC](#)

AI 1.0

Europe's Brain Project ...

- The Human Brain Project (HBP) is one of the three FET (Future and Emerging Technology) Flagship projects.
- **Started in 2013**, it is one of the largest research projects in the world. More than 500 scientists and engineers at over 140 universities, teaching hospitals, and research centres across Europe come together to address one of the most challenging research targets – the human brain.
- The Human Brain Project aims to put in place a cutting-edge research infrastructure that will allow scientific and industrial researchers to advance our knowledge in the fields of **neuroscience**, **computing**, and **brain-related medicine**.



Human Brain Project

500+

Researchers

16

Countries

607 M

Euro*

123

Institutions

10

Years**

2,000

Publications

1

Research infrastructure:



EBRAINS

* including partner contributions

** 2013-2023

Advocation of Thinking Machine ...

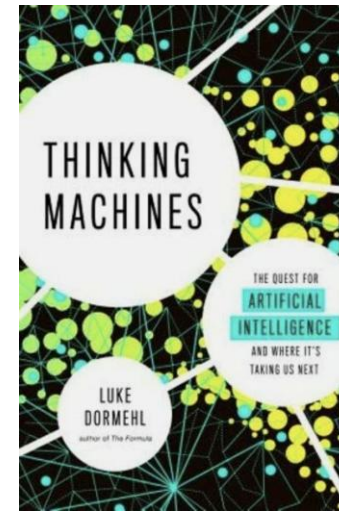
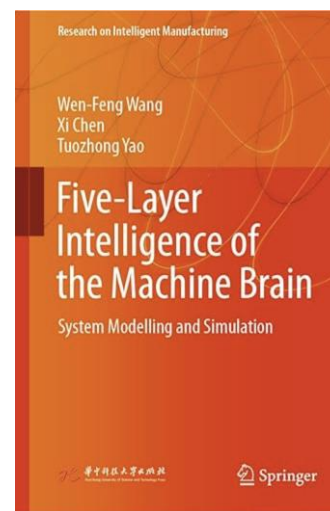
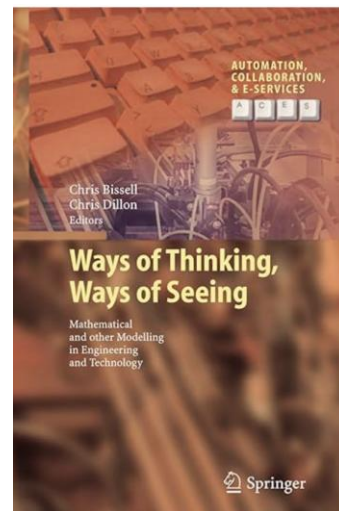
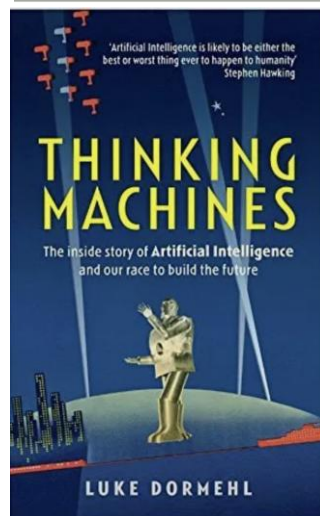
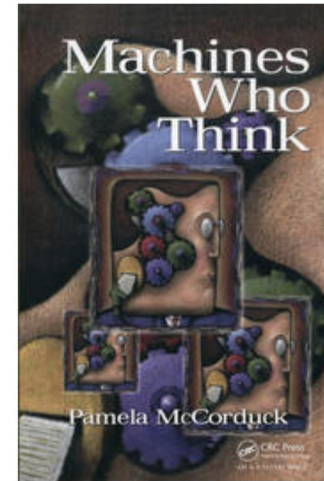
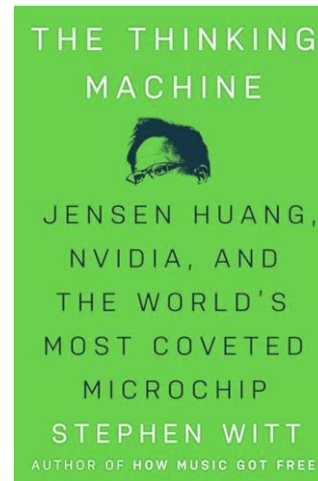
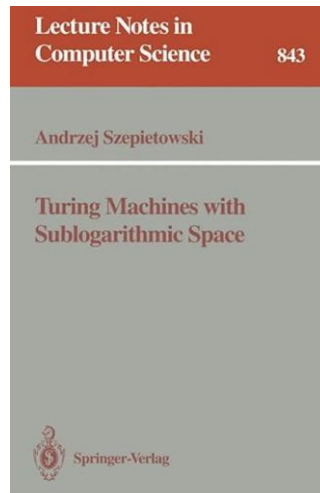

AI 1.0

A Special Belief About Relationship Between Brain and Intelligence ...

Question:

If a machine could not learn or could not be teachable, how could it think in general?



Outline of Lecture 1

- AI 1.0: Machine Thinking
- **AI 2.0: Machine Learning**
- AI 3.0: Machine Self-Intelligence
- Overview of Machine's Visual Intelligence

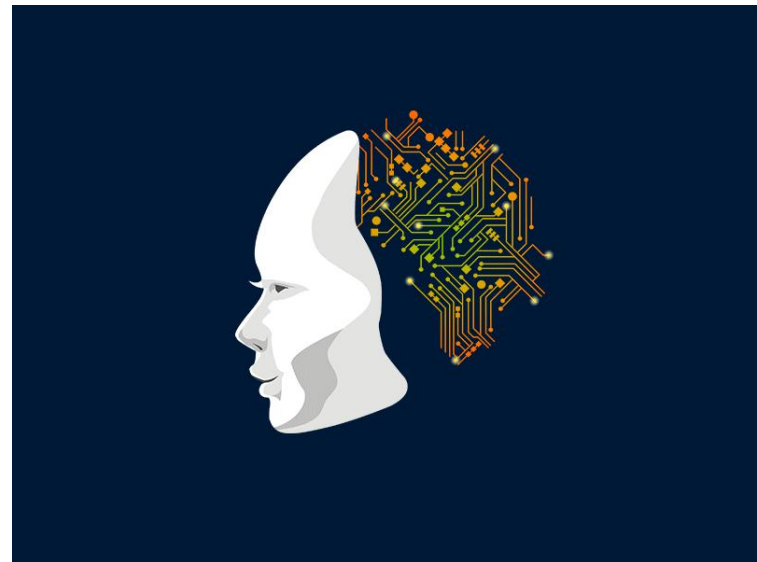

A Special Person ...

- The term *machine learning* was coined in 1959 by [Arthur Samuel](#), an [IBM](#) employee and pioneer in the field of [computer gaming](#) and [artificial intelligence](#). The synonym *self-teaching computers* was also used in this time period.
- Although the earliest **machine learning** model was introduced in the 1950s when [Arthur Samuel](#) invented a [program](#) that calculated the winning chance in checkers for each side, the history of [machine learning](#) roots back to decades of human desire and effort to study human cognitive processes.

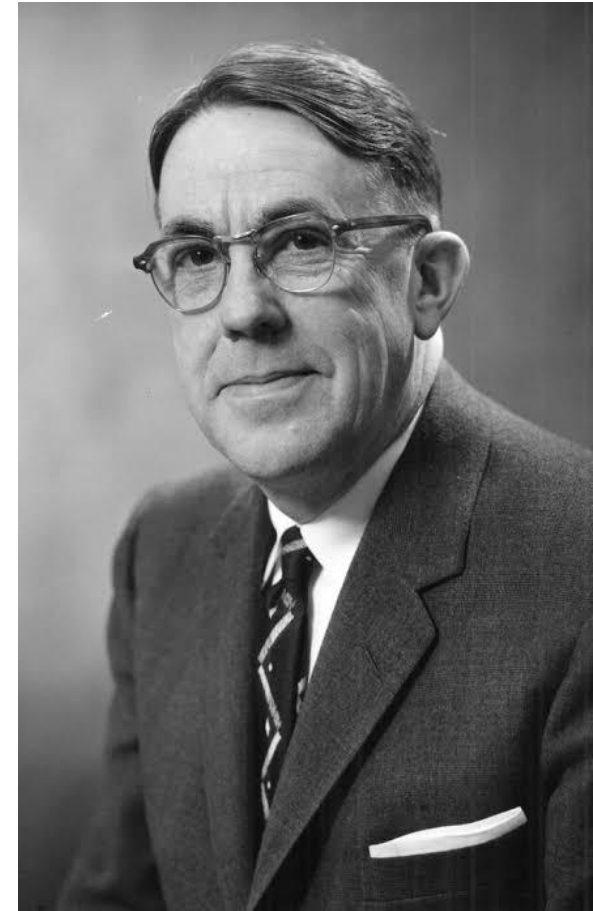

A Special Abuse of Terminology ...

- People still believe the following misleading description of **machine learning** ...
- Statistics and mathematical optimisation (mathematical programming) methods comprise the foundations of machine learning. Data mining is a related field of study, focusing on exploratory data analysis (EDA) via unsupervised learning.
- **Machine learning (ML)** is a field of study in artificial intelligence concerned with the development and study of statistical algorithms that can learn from data and generalise to unseen data, and thus perform tasks without explicit instructions. Within a subdiscipline in machine learning, advances in the field of deep learning have allowed neural networks, a class of statistical algorithms, to surpass many previous machine learning approaches in performance.

First Winter in AI ...

History of AI

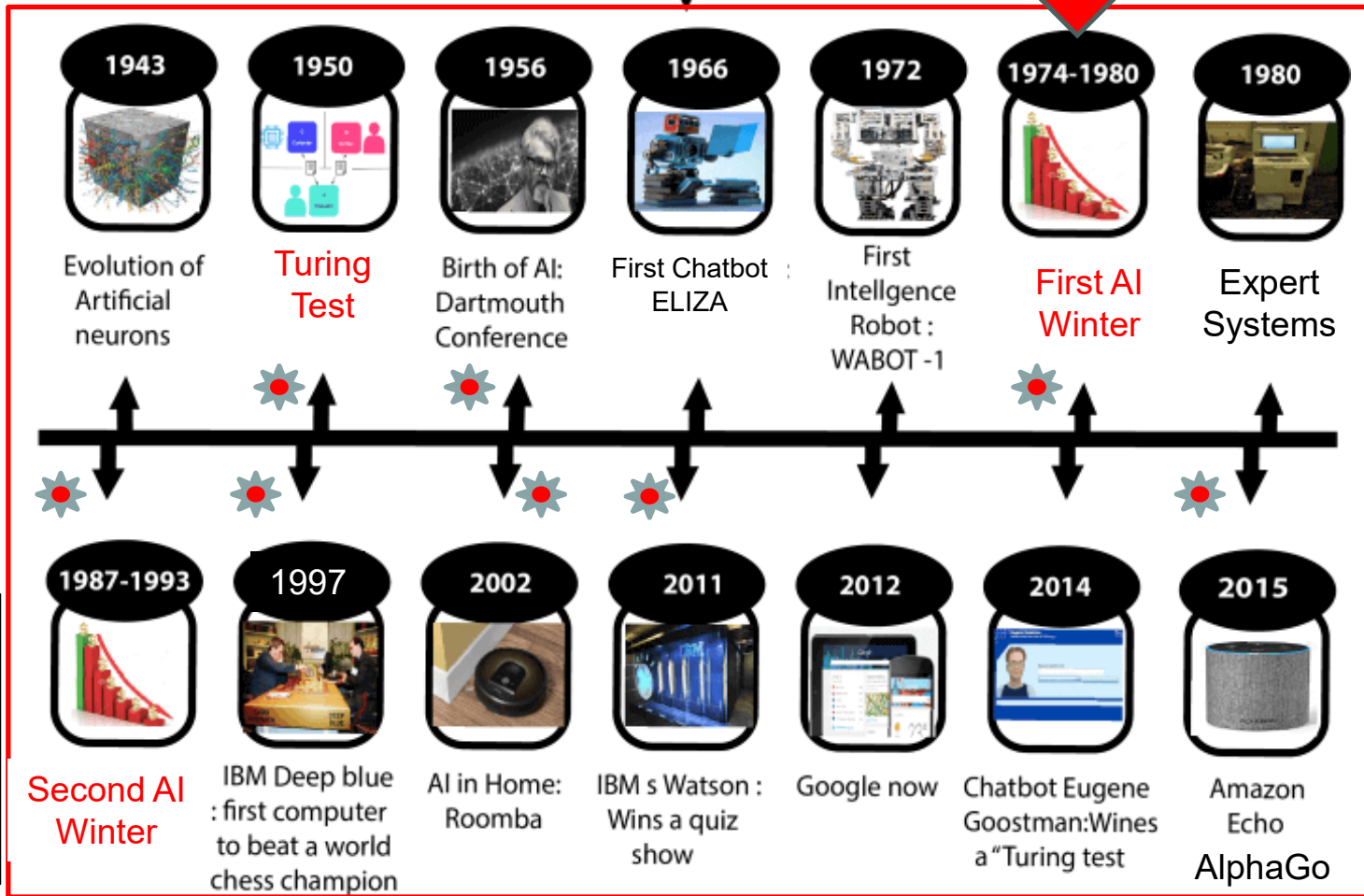

Big Question:
Does intelligence arise from brain or mind?

Advocation of Learning from Human Intelligence ...

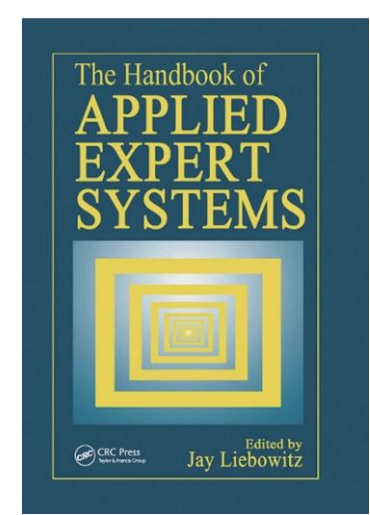
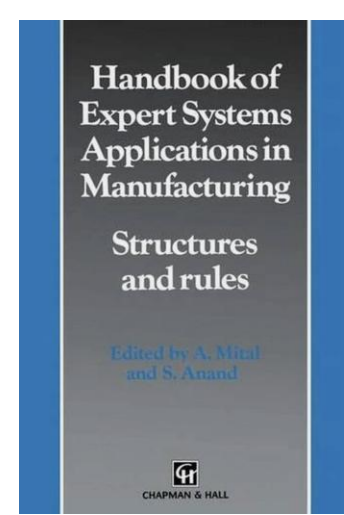
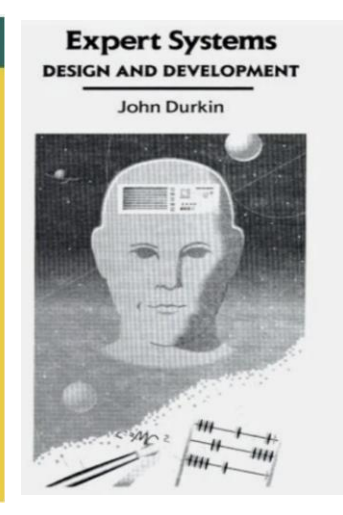
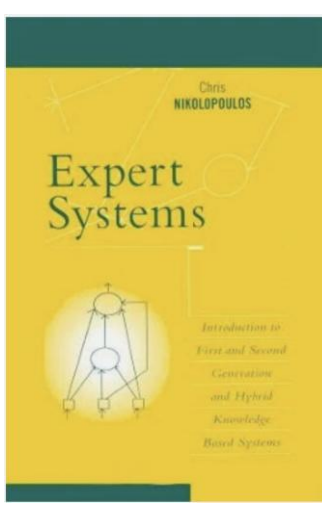
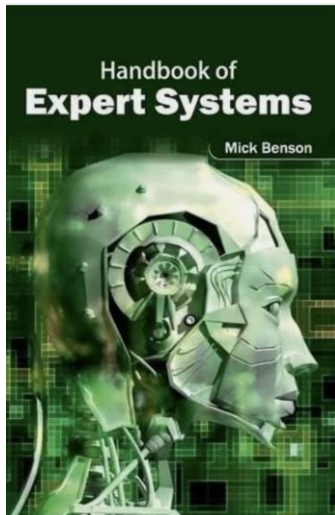
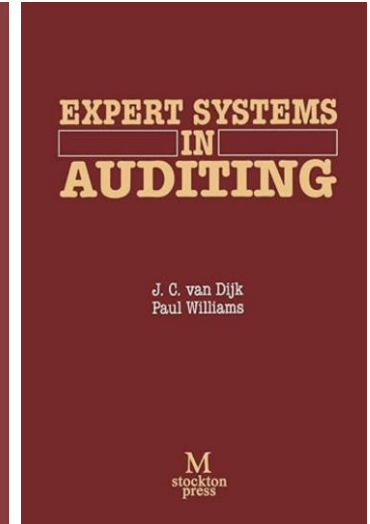
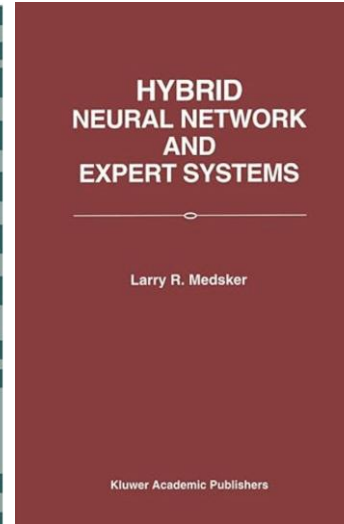
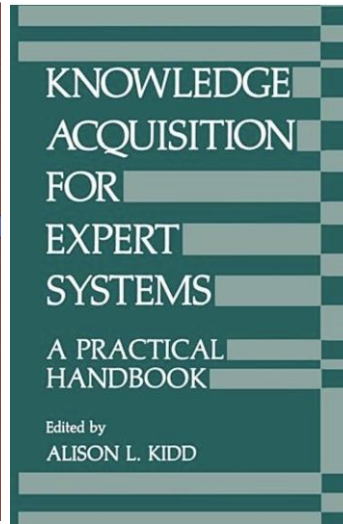
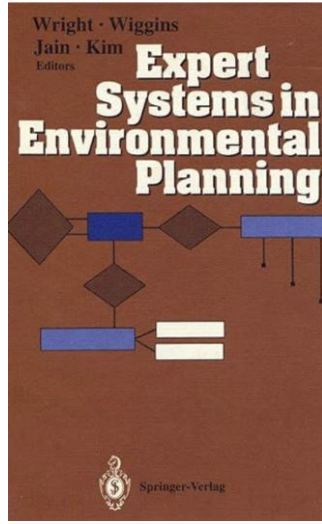
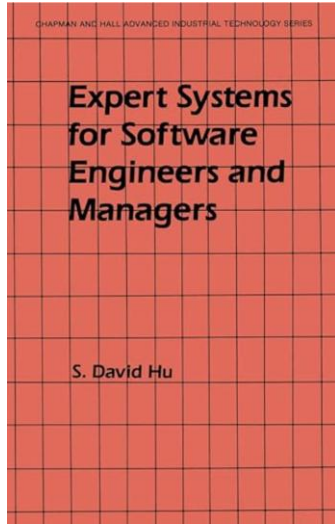

Second Winter in AI ...

History of AI

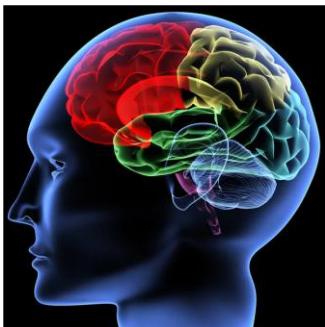
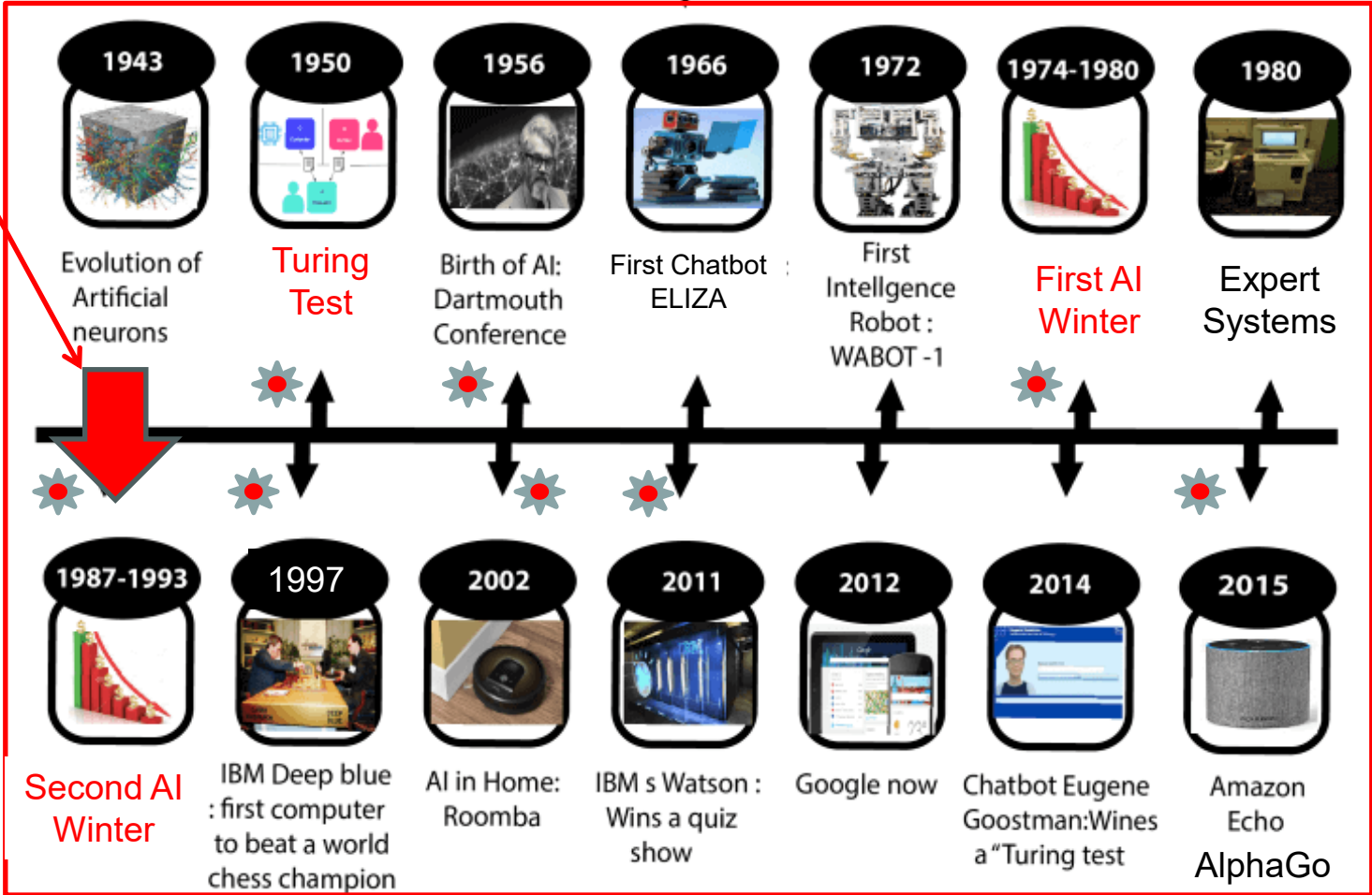

Big Question:
Does intelligence arise from brain or mind?

AI 2.0

Deep Blue Project: Computer-Aided Human Intelligence ...

- **Deep Blue** was a chess-playing computer developed by IBM. It is known for being the first computer chess-playing system to win both a chess game and a chess match against a reigning world champion under regular time controls.
- Deep Blue won its first game against a world champion on **10 February 1996**, when it defeated Garry Kasparov in game one of a six-game match.

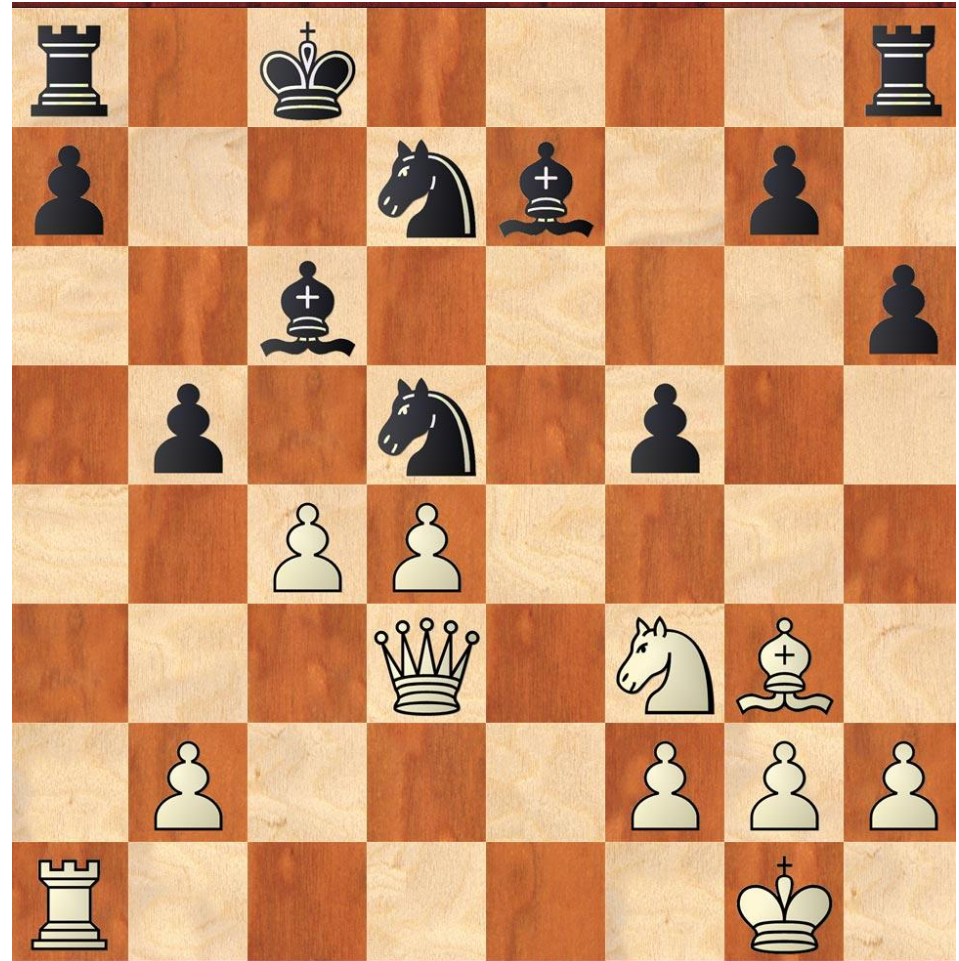

AI 2.0

Alpha Go Project: Computer-Aided Human Intelligence ...

- **AlphaGo** is a computer program that plays the board game Go. It was developed by Alphabet Inc.'s Google DeepMind in London.
- In **October 2015**, AlphaGo became the first computer Go program to beat a human professional Go player without handicaps on a full-sized 19×19 board.
- In **March 2016**, it beat Lee Sedol in a five-game match, the first time a computer Go program has beaten a 9-dan professional without handicaps.

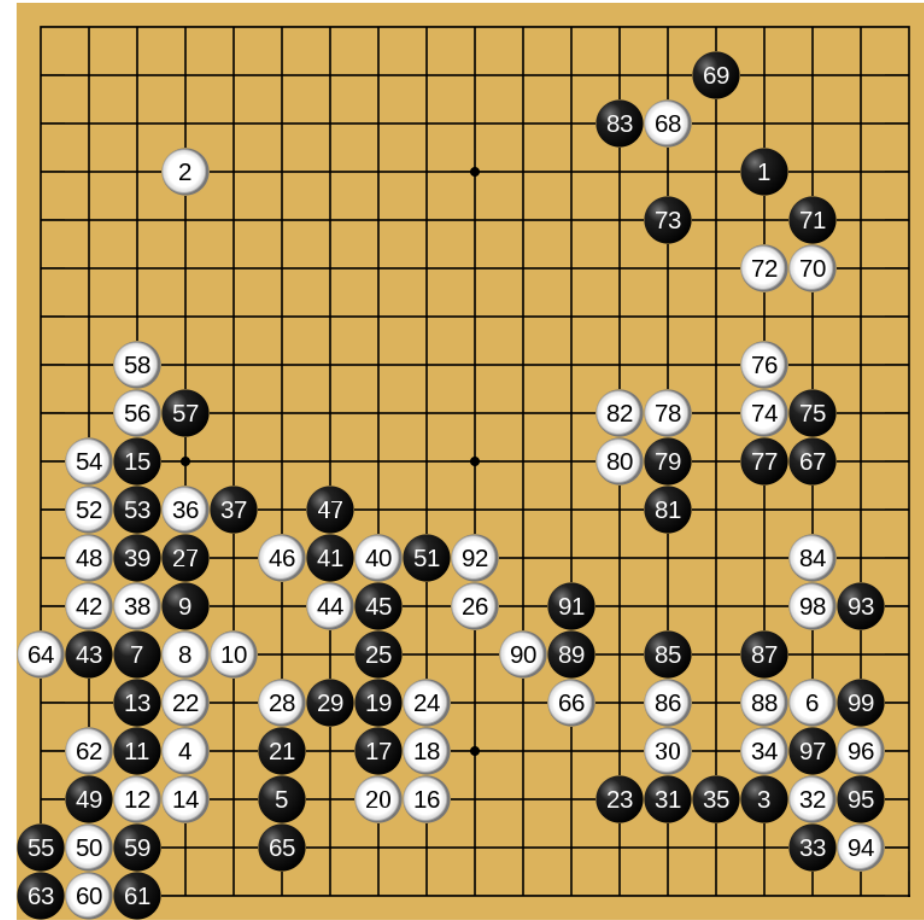

AI 2.0

Is Deep Machine Tuning equal to Deep Machine Learning? (from MIT)

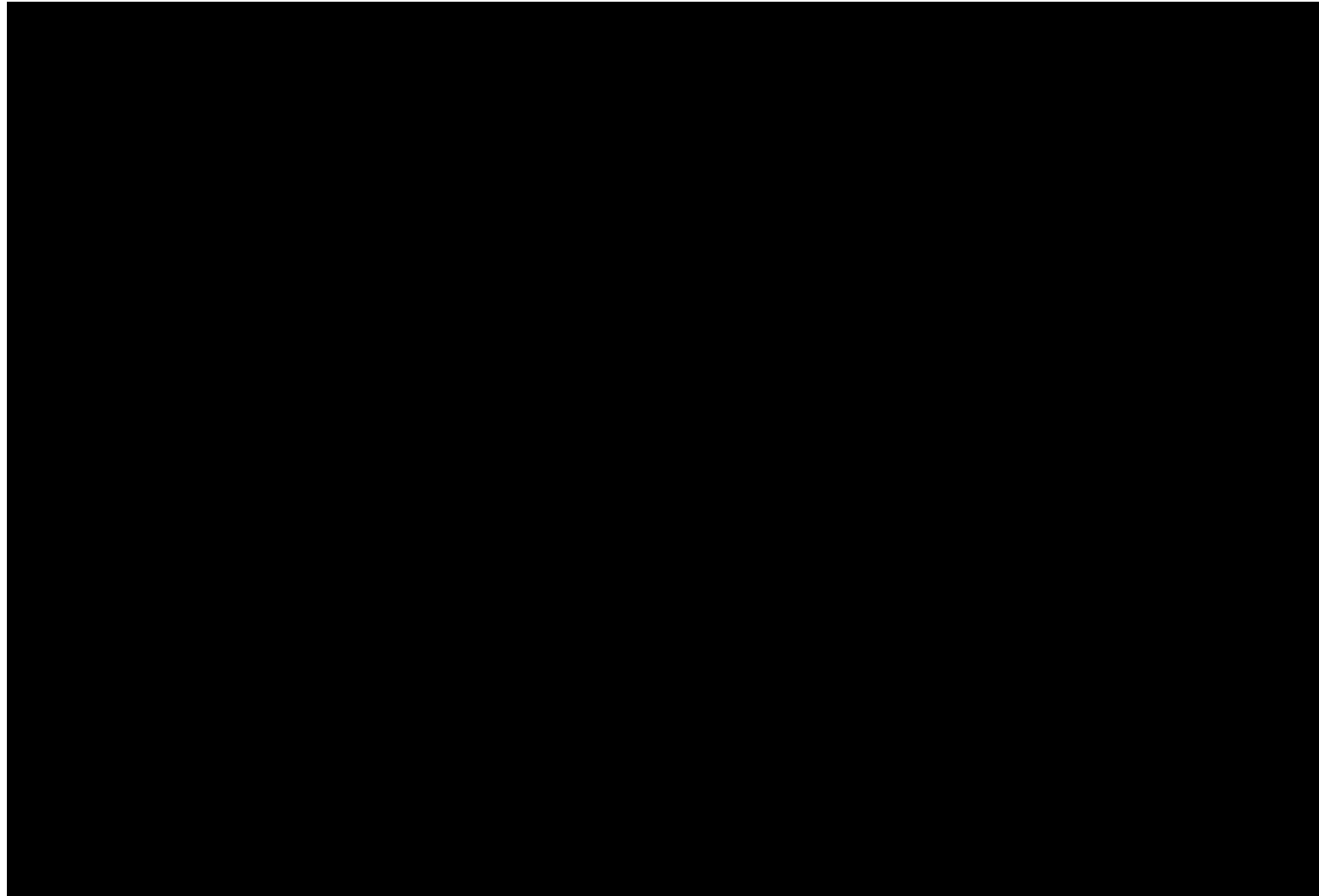

Example of Machine's Fake Learning



8-12 JANUARY 2024

GLOBAL YOUNG SCIENTISTS SUMMIT

EXCITE • ENGAGE • ENABLE

Organised by
NATIONAL RESEARCH FOUNDATION
PRIME MINISTER'S OFFICE
SINGAPORE



Adversarial Examples:

- Were discovered in 2013 by Szegedy et al and Biggio et al
- Have major security implications and applications



88% tabby cat

adversarial
perturbation →



99% guacamole

Salad made of avocado

AI 2.0

Another Example of Machine's Fake Learning ...



8-12 JANUARY 2024

GLOBAL YOUNG SCIENTISTS SUMMIT

EXCITE • ENGAGE • ENABLE

Organised by
NATIONAL RESEARCH FOUNDATION
PRIME MINISTER'S OFFICE
SINGAPORE



Pigs can fly:

"pig"



+ 0.005 x

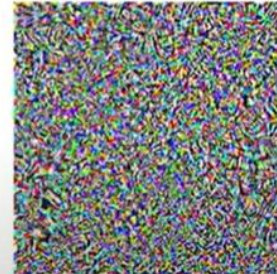

=

"airliner"



Optimization is not learning ...

The image shows a presentation slide on a screen. The slide has a blue header with the quote: "The most common mistake of a smart engineer is to optimize something that should not exist" attributed to Elon Musk. To the right of the quote is a portrait of Elon Musk. Below the quote is a Venn diagram with two overlapping circles: a grey one labeled "AI / Engineering Approaches" and a green one labeled "Clinical Medicine". Below the Venn diagram is another quote: "Of all the ways you *could* apply AI / engineering techniques to medicine, 99.9% of them are clinically uninteresting" attributed to Dr. Bunsen Honeydew. To the left of this quote is a cartoon image of Dr. Bunsen Honeydew. At the bottom left of the slide, there are small navigation icons.

"The most common mistake of a smart engineer is to optimize something that should not exist"
Elon Musk

AI / Engineering Approaches Clinical Medicine

*"Of all the ways you **could** apply AI / engineering techniques to medicine, 99.9% of them are clinically uninteresting"*
Dr. Bunsen Honeydew

Computation is not learning

- Computational Neural Network (i.e. ComNN)

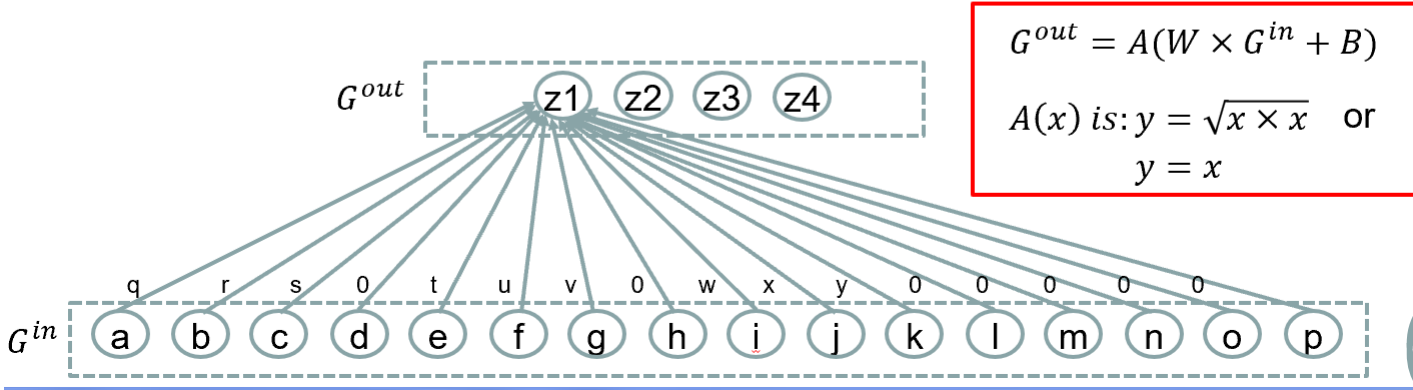
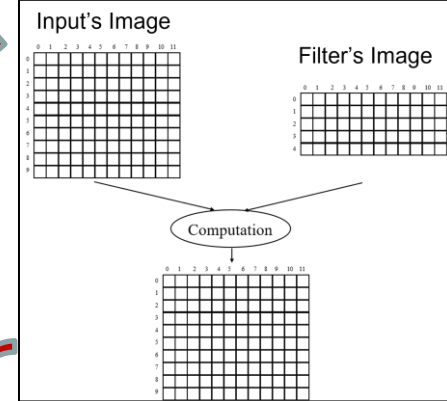
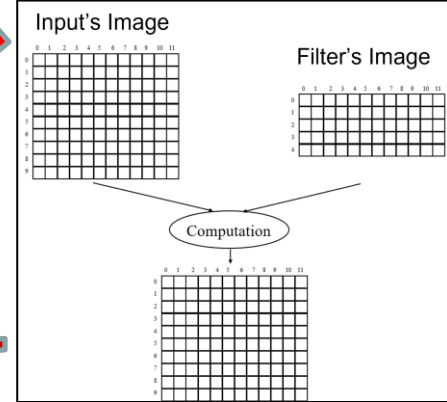
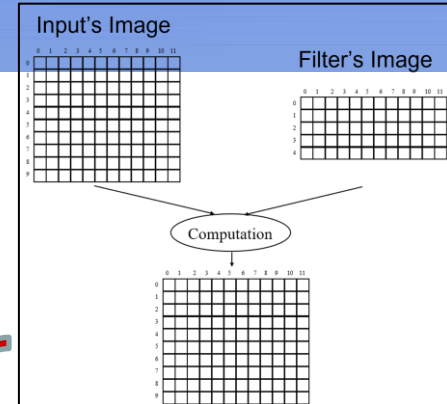
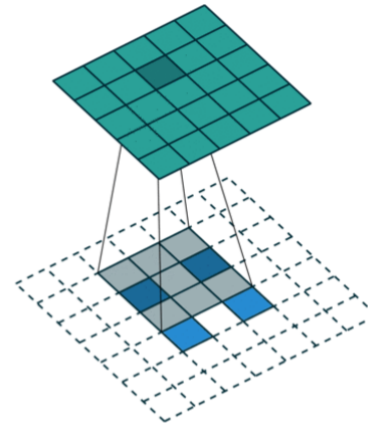
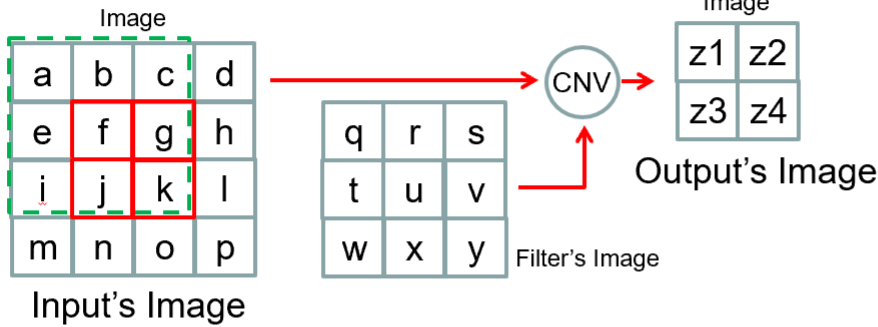

AI 2.0

Calibration is not learning ...

Self-attention

<https://arxiv.org/abs/1706.03762>

q : query (to match others)

$$q^i = W^q a^i$$

k : key (to be matched)

$$k^i = W^k a^i$$

v : information to be extracted

$$v^i = W^v a^i$$

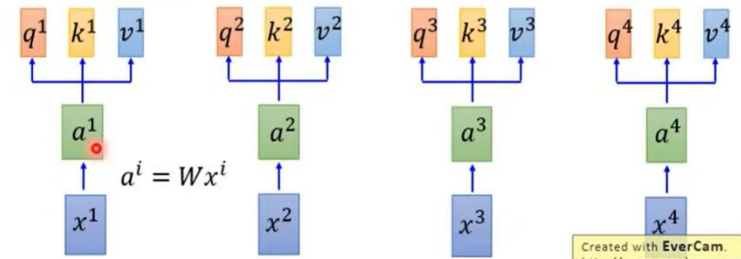

Self-attention

$$\hat{\alpha}_{1,i} = \exp(\alpha_{1,i}) / \sum_j \exp(\alpha_{1,j})$$

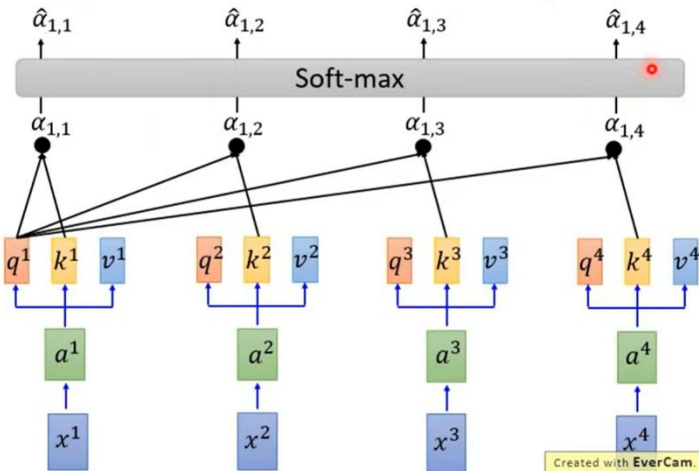

Self-attention

拿每個 query q 去對每個 key k 做 attention

d is the dim of q and k

$$\text{Scaled Dot-Product Attention: } \alpha_{1,i} = \frac{q^1 \cdot k^i}{\sqrt{d}}$$

dot product

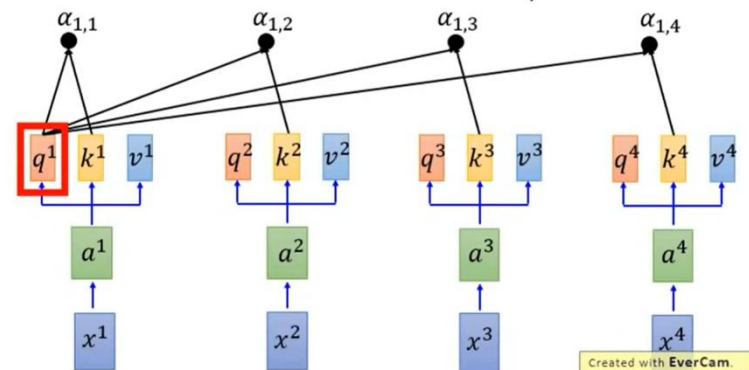

AI 2.0

Tuning is not learning ...

Self-attention $\hat{\alpha}_{1,i} = \exp(\alpha_{1,i}) / \sum_j \exp(\alpha_{1,j})$

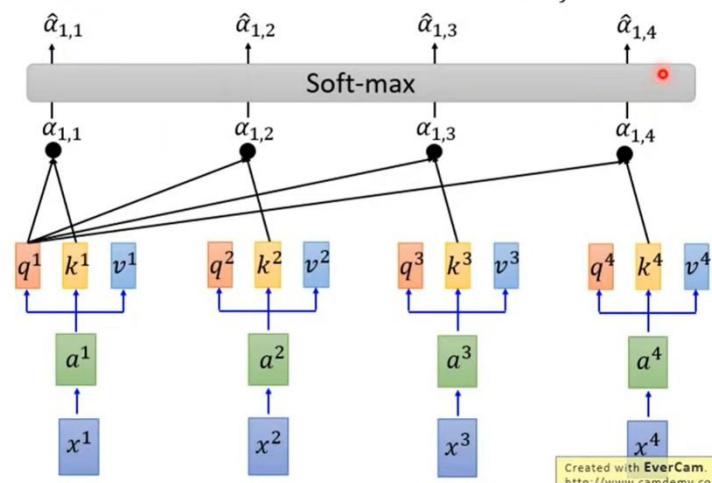

Self-attention $b^1 = \sum_i \hat{\alpha}_{1,i} v^i$

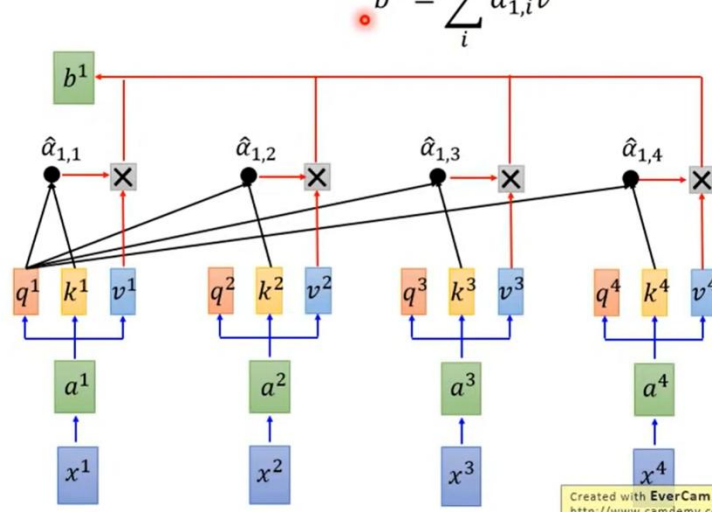

Self-attention

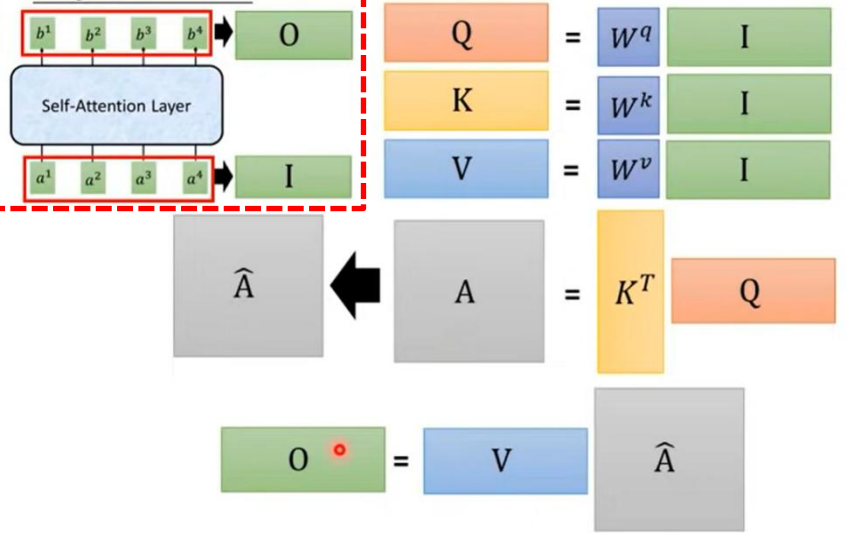

AI 2.0

A Special Belief About Relationship Between Brain and Intelligence ...

Question:

If a machine does not have self-intelligence or is not teachable, how could it learn in general?



Outline of Lecture 1

- AI 1.0: Machine Thinking
- AI 2.0: Machine Learning
- **AI 3.0: Machine Self-Intelligence**
- Overview of Machine's Visual Intelligence

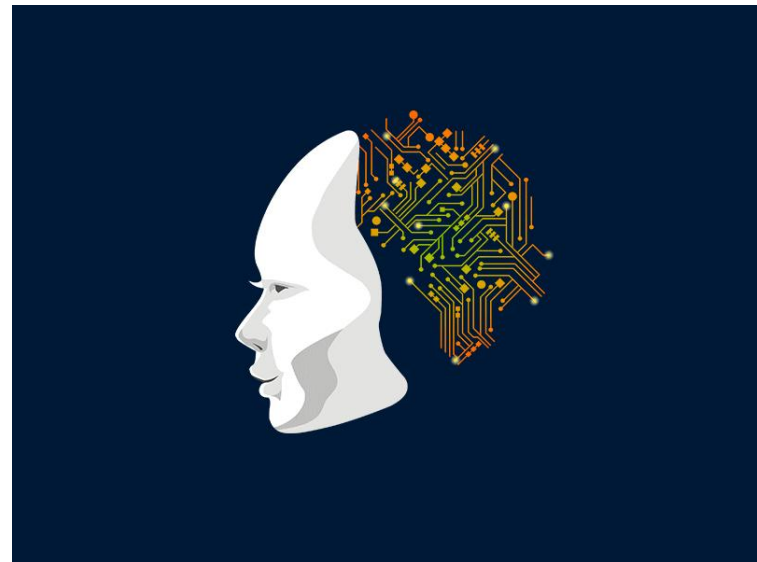

Warm-Up Question 1

- Which one of the following two terminologies is a synonym for Artificial Intelligence?
 - A) Artificial Brain
 - B) Artificial Mind



Evidence

...

Scientists research man missing 90% of his brain who leads a normal life

CBC Radio · Posted: Jul 14, 2016 5:27 PM EDT | Last Updated: April 17, 2023

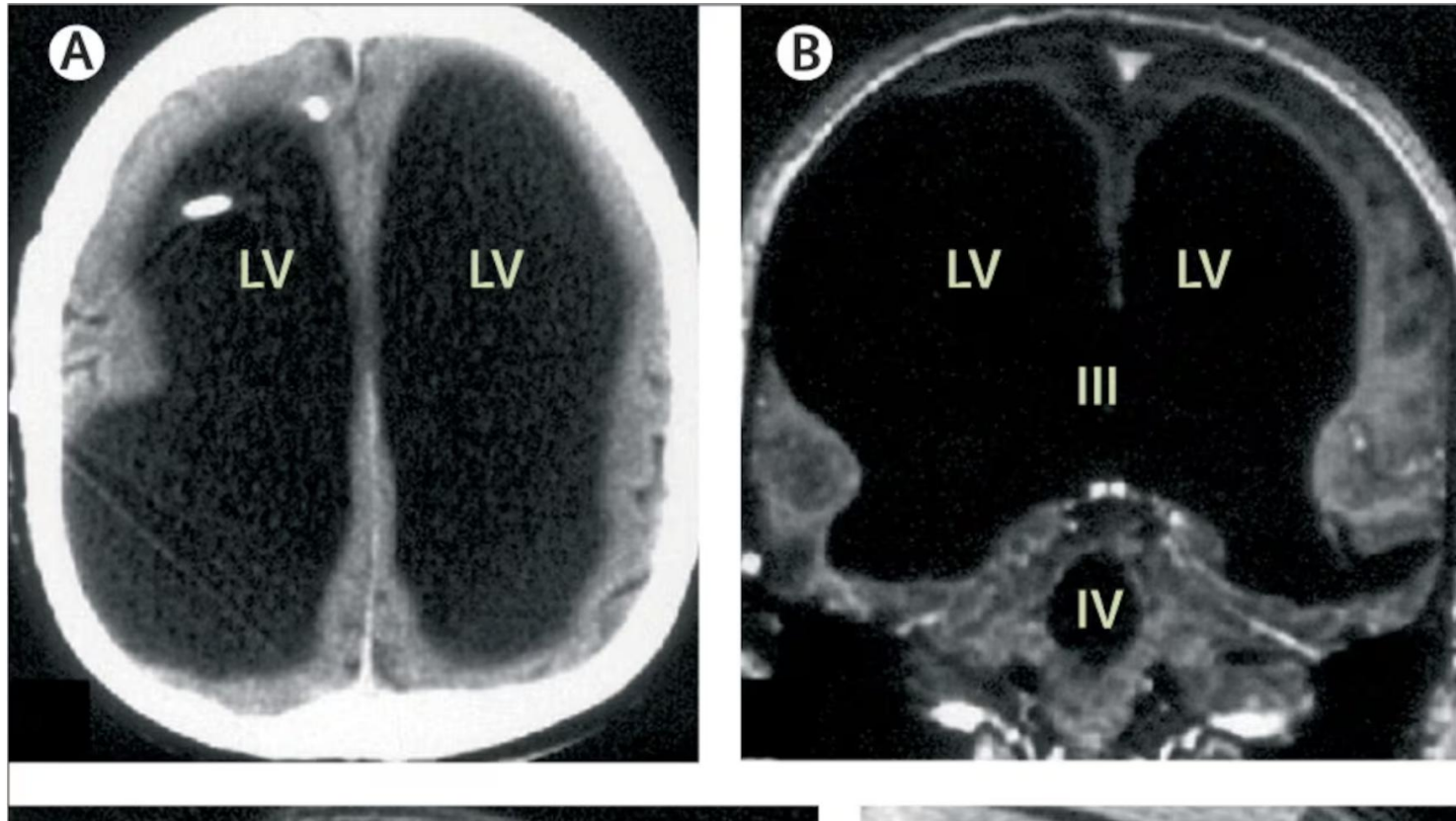

These scans of a French man's brain were published in *The Lancet* in 2007. Since then, this case has puzzled researchers, including cognitive psychologist Axel Cleeremans. (Feuillet et al/*The Lancet*)

Many Other Evidences ...

- ▶ J Undergrad Neurosci Educ. 2016 Apr 15;15(1):C1–C3.

The Woman Born Without a Cerebellum: A Real-Life Case Adapted for Use in an Undergraduate Developmental and Systems Neuroscience Course

[Jennifer Brielmaier](#)^{1,✉}

- ▶ Author information
- ▶ Article notes
- ▶ Copyright and License information

PMCID: PMC5105972 PMID: [27980478](#)

Abstract

In 2014, the case of a 24-year-old woman who had just discovered she was born without a cerebellum made headlines around the world. The details of this case were combined with

Warm-Up Question 2

- Which one of the following four terminologies is a synonym for Learning?
 - A) Cognition
 - B) Optimization
 - C) Tuning
 - D) Calibration



Warm-Up Question 3

- Which one of the following four transformations is not a process of Authentic AI?
 - A) Signal to Signal
 - B) Signal to Knowledge
 - C) Knowledge to Knowledge
 - D) Knowledge to Signal



Authentic AI versus Fake AI

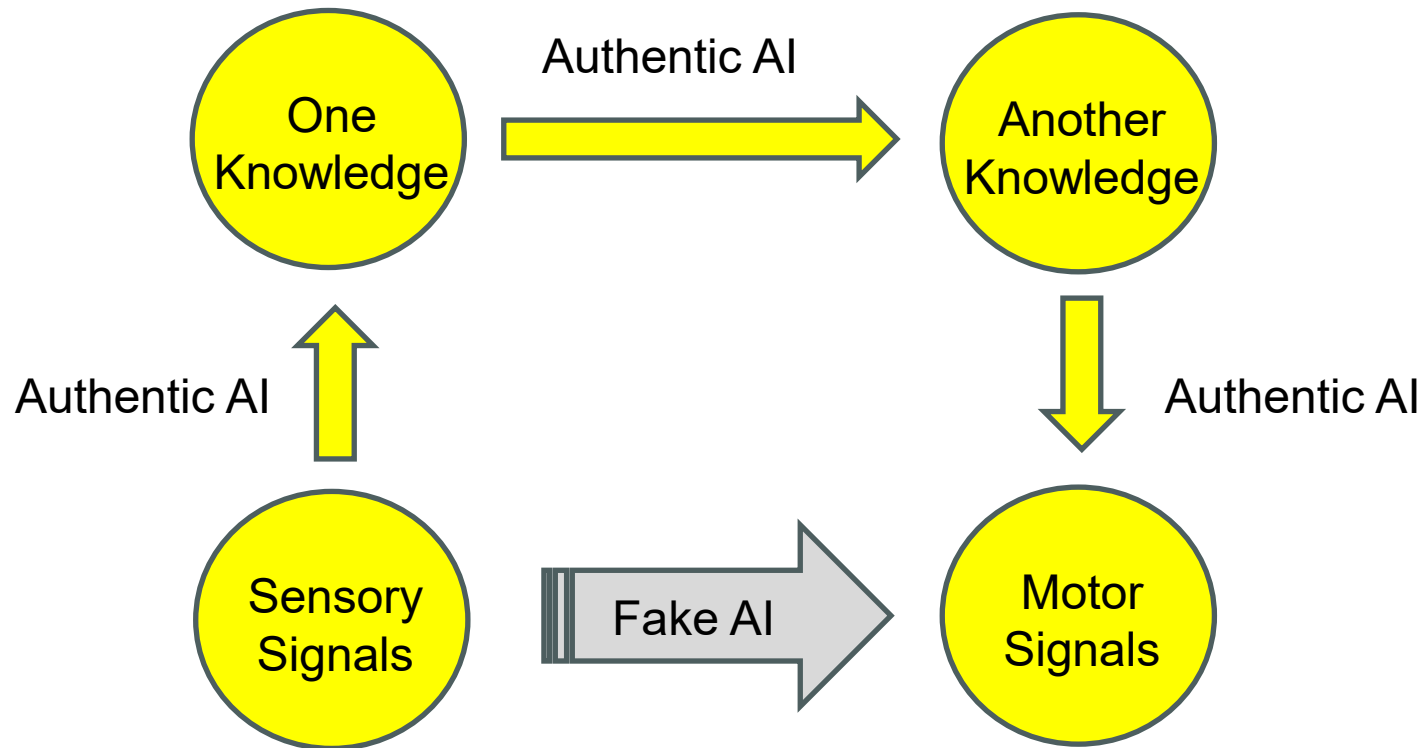

Rebirth of AI ...

History of AI

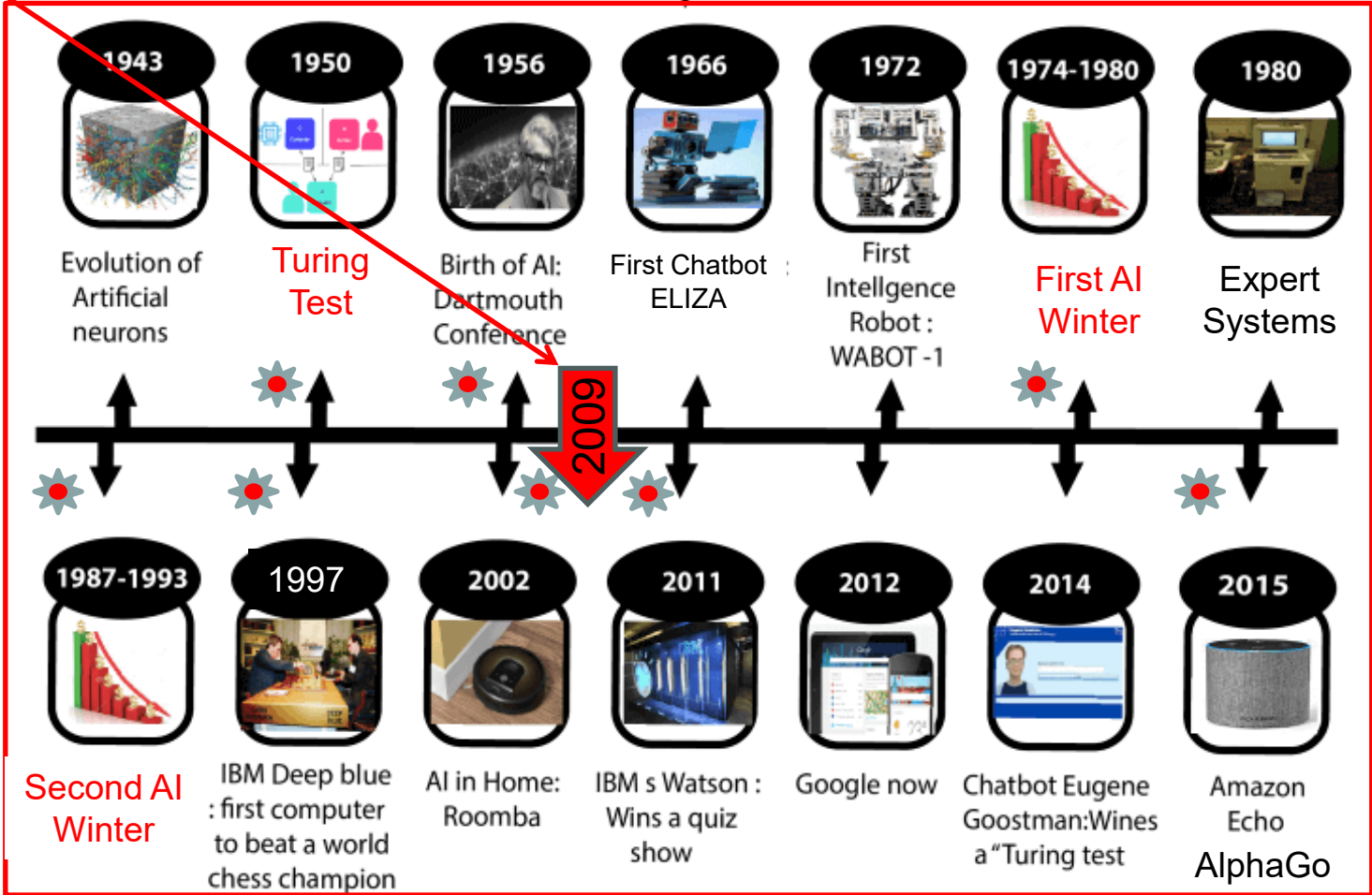

Big Question:
Does intelligence arise from brain or mind?

Special Pattern of AI's History

AI is enjoying significant hype and investment

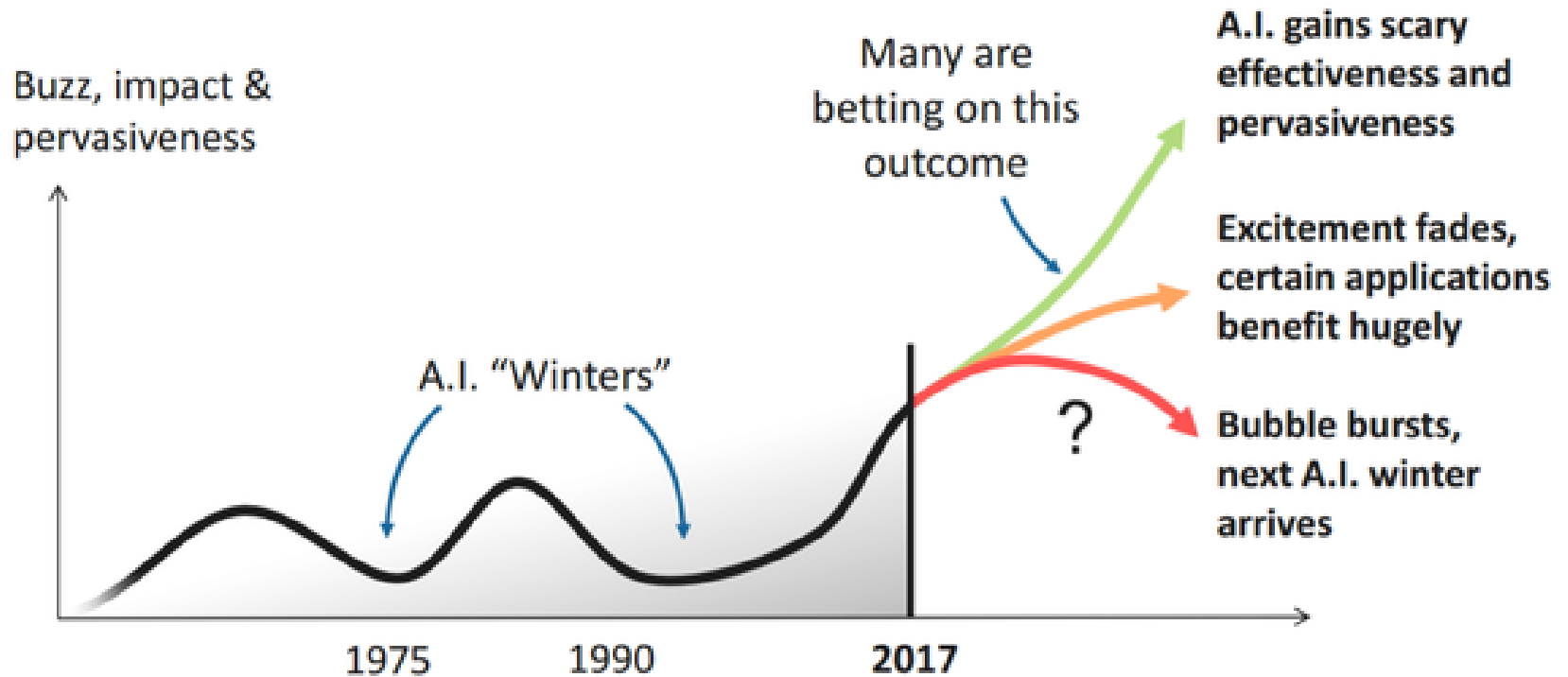

→ 2009	AI 3.0 (Machine Self-Intelligence) (机器内智) (自具之智, 人赋)
2000	AI 2.0 (Machine Learning) (机器学习)
1956	AI 1.0 (Machine Thinking) (机器思考)

DARPA's Viewpoints (Wave 1)

The first wave of AI

The first wave of AI

Perceiving
Learning
Abstracting
Reasoning

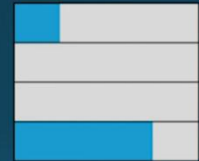

Handcrafted Knowledge



2017.2

DARPA's Viewpoints (Wave 2)

The second wave of AI

Statistical Learning



The second wave of AI

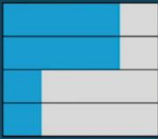

- Perceiving
- Learning
- Abstracting
- Reasoning

2017.2

DARPA's Viewpoints (Wave 3)

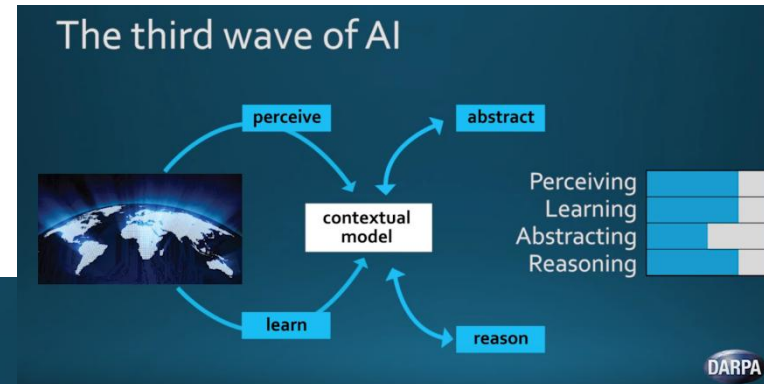

The (future) third wave of AI

Contextual Adaptation

Systems construct explanatory models
for classes of real world phenomena



2017.2

China's Viewpoints (AI 2.0)

2017-6

2017 世界智能大会 WIC



中国新一代人工智能

New-Generation AI in China

潘云鹤 PAN Yunhe

中国工程院院士
中国工程院原常务副院长
Academician of the Chinese Academy of Engineering
Former Executive Vice President of the Chinese Academy of Engineering

走向智能论坛

(一) 几种巨变促使人工智能迈向新一代

- 信息环境巨变:**
 - 互联网、移动计算、超级计算、穿戴设备、物联网、云计算、网上社区、万维网、搜索引擎.....
- 社会新需求爆发:**
 - 智能城市、智能医疗、智能交通、智能游戏、无人驾驶、智能制造.....
- AI的基础和目标巨变:**
 - 大数据、多媒体、传感器网、增强现实 (AR)、虚拟现实 (VR).....
 - 计算机模拟人的智能-人机融合-群体智能

人工智能迈向新一代

中国工程院 CHINESE ACADEMY OF ENGINEERING

走向智能论坛

项目专家组进而认为：重要的是，人工智能不仅会有量的大发展，而且将进入一次质的大飞跃，中国应予以前瞻性研究，**尽快布局，率先策动。**

走向智能论坛

中国工程院 Chinese Academy of Engineering

中国新一代人工智能

中国工程院 潘云鹤
2017年6月29日 天津

走向智能论坛

二、人工智能走向2.0

走向智能论坛

中国新一代人工智能的建议研究方向

类别	方向
AI2.0 技术与软件	大数据智能
	群体智能
	跨媒体智能
	人机混合增强智能
	自主智能系统
应用	智能城市、智慧医疗、智能制造等等

走向智能论坛

What are the root causes behind such pattern of AI history?

AI is enjoying significant hype and investment

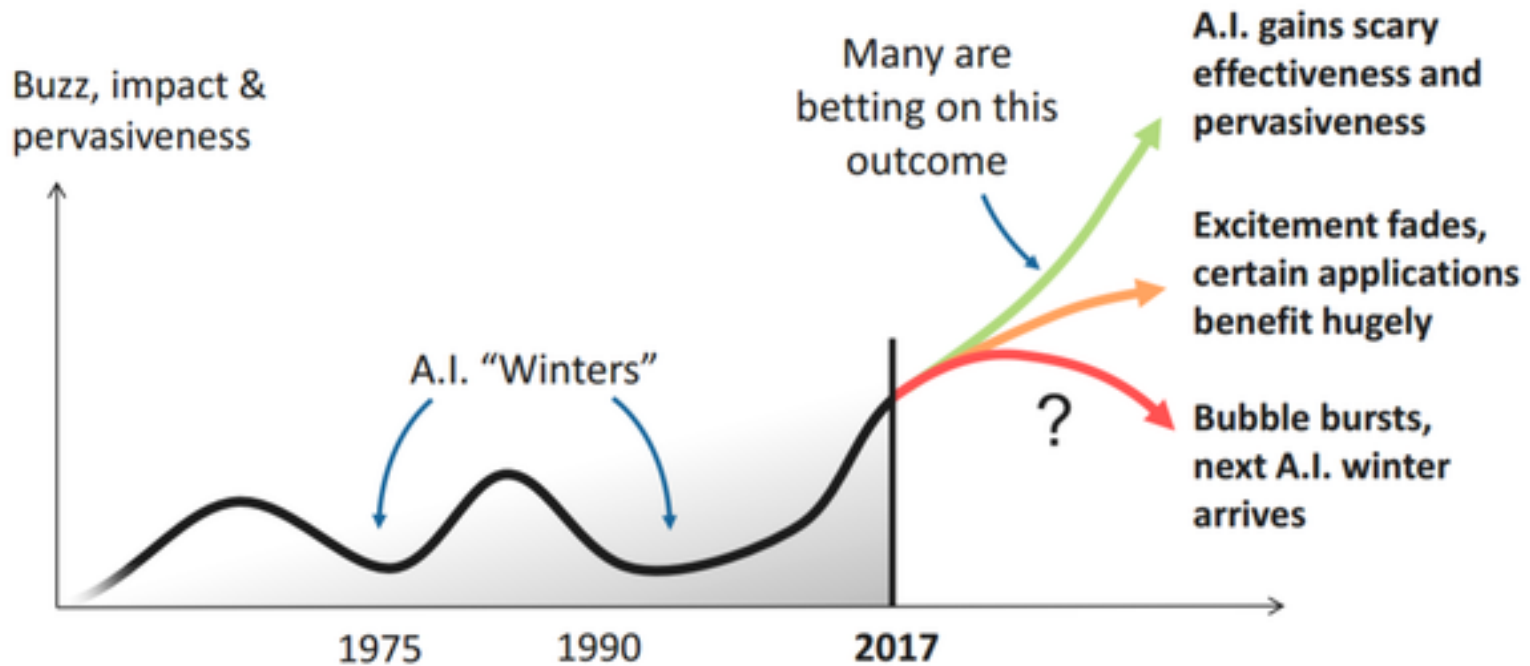

- 2009 AI 3.0 (Machine Self-Intelligence) (机器内智) (自具之智, 人赋)
- 2000 AI 2.0 (Machine Learning) (机器学习)
- 1956 AI 1.0 (Machine Thinking) (机器思考)

Root Cause No.1

AI Researchers' Ignorance About Biological Manufacturing ...

- Development is a long process of biological manufacturing.
- Development of brain has nothing to do with design of mind.

▶ Quantitative changes lead to the so-called **Mechanical Manufacturing**

▶ Qualitative changes lead to the so-called **Chemical Manufacturing**

▶ Fissions lead to the so-called **Biological Manufacturing**

Example of Biological Manufacturing

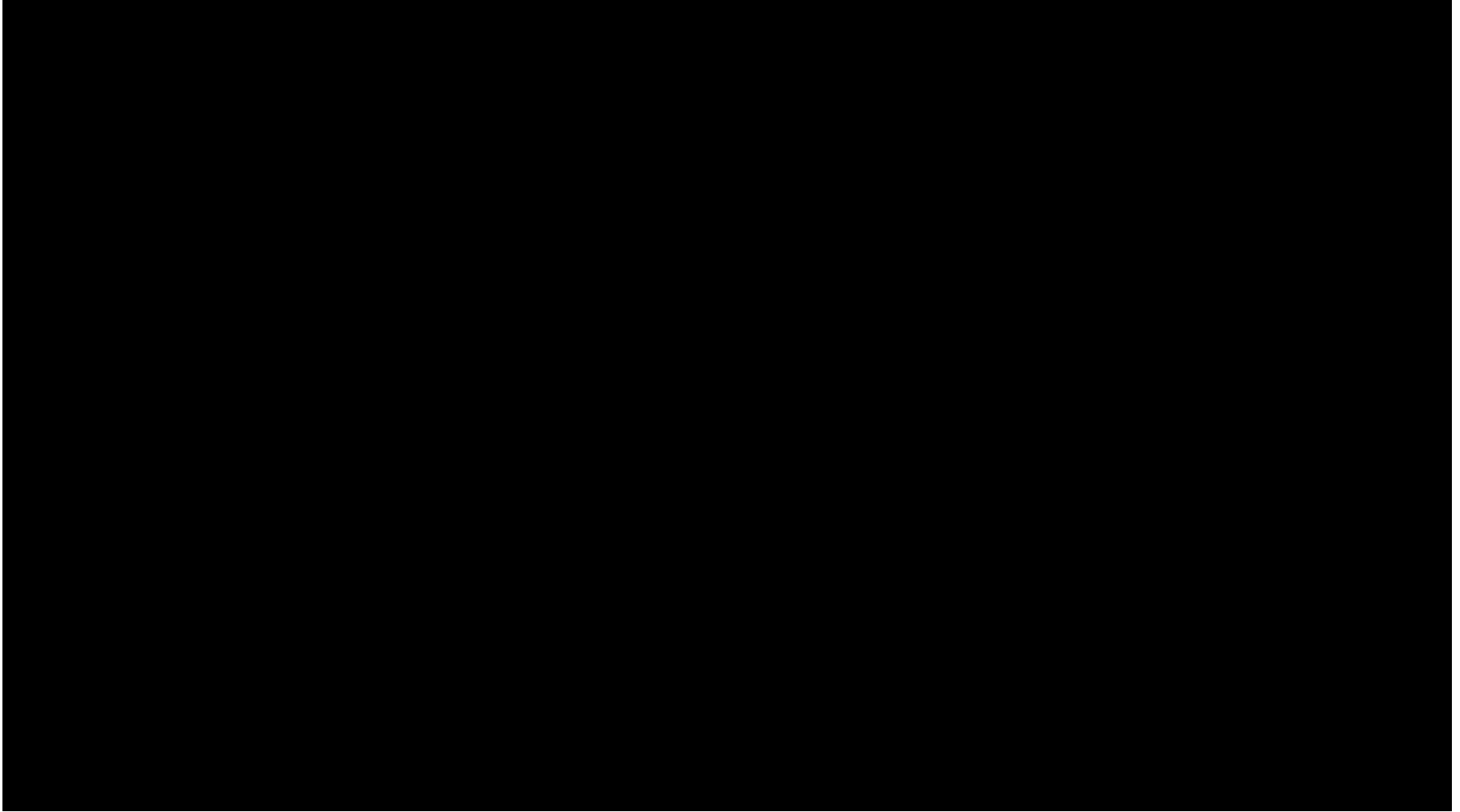

Root Cause No.2

A Special Book in AI ...

- It is used in over **1400 universities** worldwide and has been called "**the most popular artificial intelligence textbook in the world**". It is considered the standard text in the field of artificial intelligence.
- The editions of the book include:
 - 1st Edition, 904 pages, 1995
 - **2nd Edition, 1043 pages, 2003**
 - 3rd Edition, 1093 pages, 2010
 - New Edition, 1152 pages, 2021

The book considers that robotics is part of AI

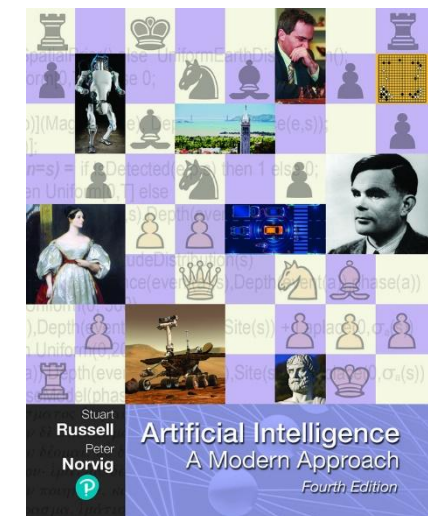
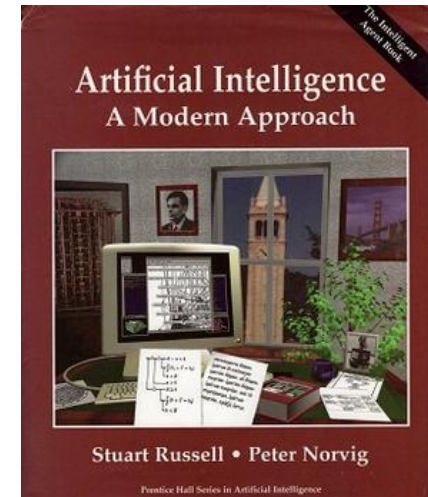

Root Cause No.3

An Implicit Definition of Artificial Intelligence ...

- Many people believe that Artificial Intelligence refers to **computer-aided human intelligence**, which aims at programming human ways of doing perception, planning and action.
- **Computer-aided Intelligence is not equal to Computer Intelligence!**

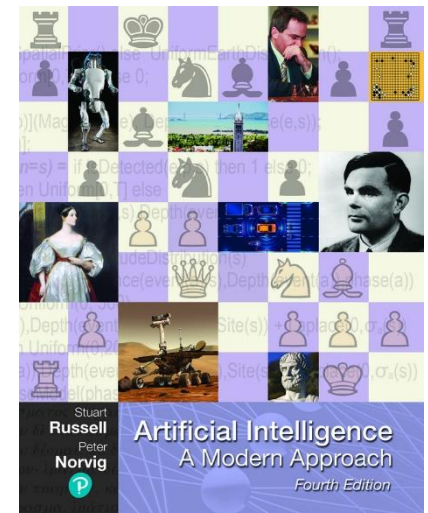
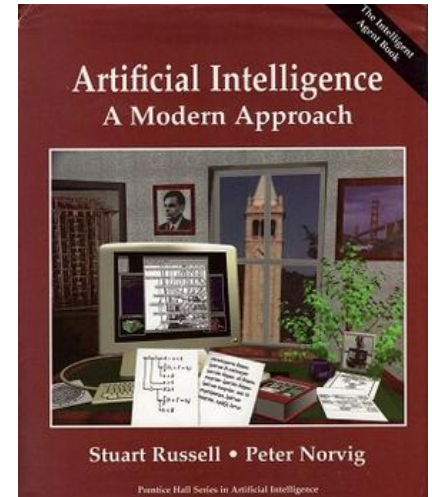

How to clear the misconceptions in Artificial Intelligence? ...

AI 1.0: Machine Thinking

- Artificial intelligence refers to **computer-aided human intelligence**, which aims at programming human ways of **doing reasoning, inference and decision-making**.

AI 2.0: Machine Learning

- Artificial intelligence refers to **computer-aided human intelligence**, which aims at programming human ways of **doing learning of knowledge about truths and skills**.

-
- **Computer-aided Intelligence is not equal to Computer Intelligence!**

- **Computer-aided Intelligence is not equal to Computer Intelligence!**

Speech by China's President ...

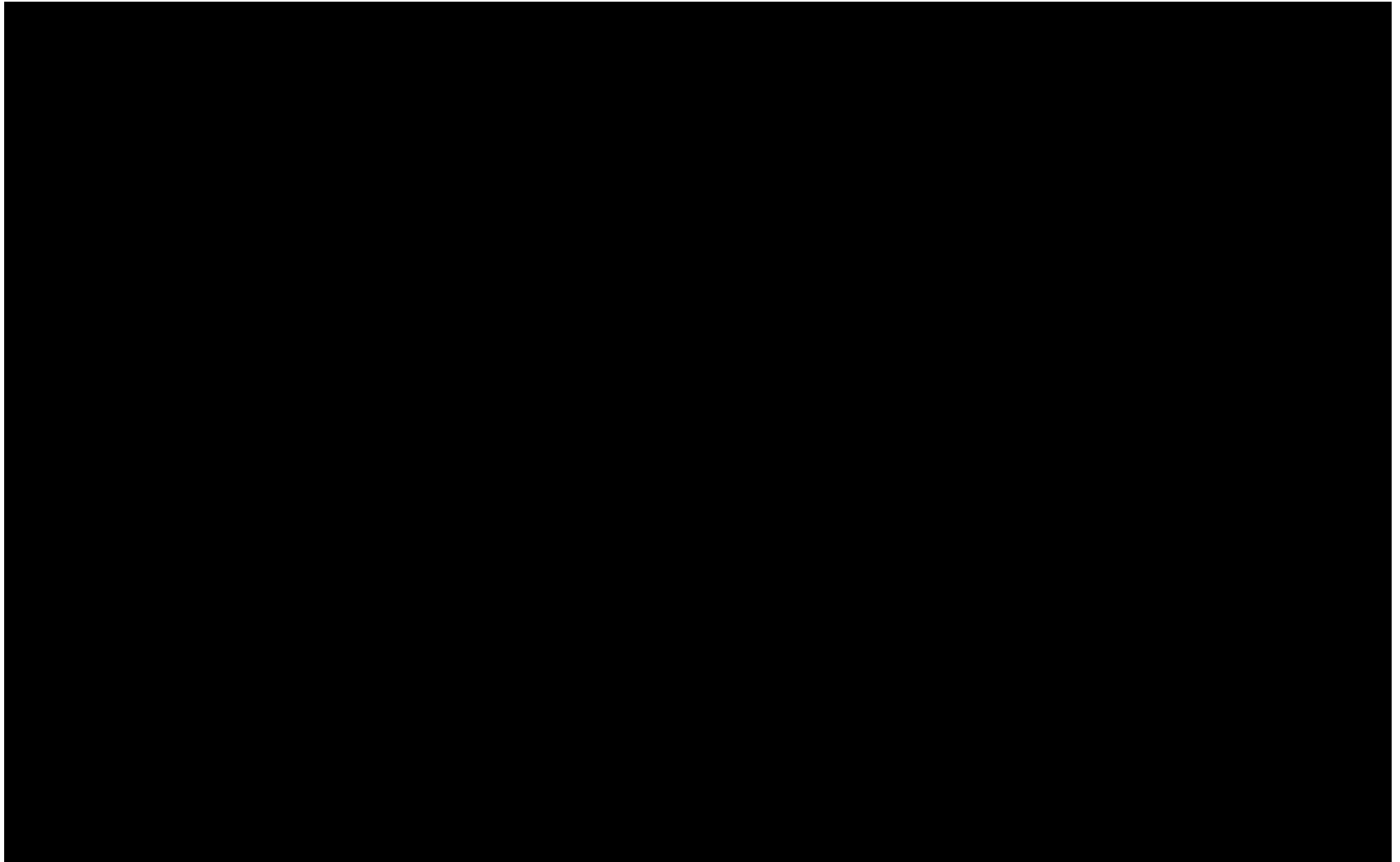

Speech by Singapore's Prime Minister ...

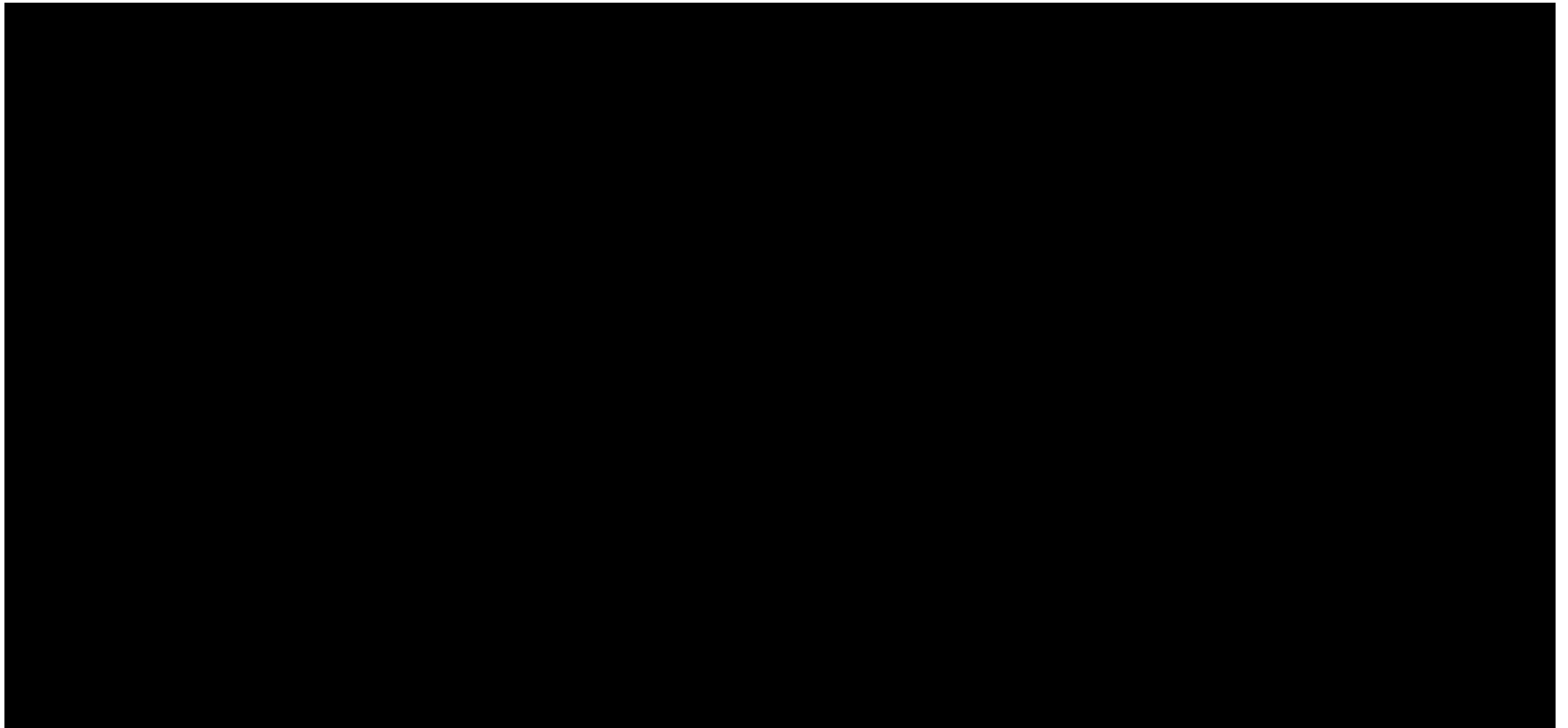

NTU's AI-Related Position Statement No. 1:

Statement 1: Explainability

Deployed AI tools should have max effort of explainability and interpretability unless there are clear benefits to the patient of black box models

Because of their complexity, such tools often provide answers beyond biological rationalization and human comprehension, are widely treated as "black boxes".

Do we require AI algorithm be 100% interpretable? It has been argued that many time-honored effective drugs such as aspirin, metformin, acetaminophen that have been used for decades with undisputed efficacy, yet their mechanism of action are still unclear.

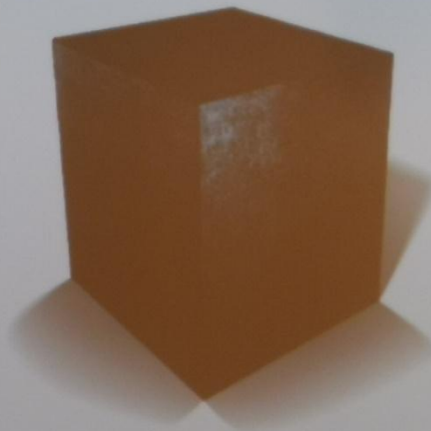

NTU's AI-Related Position Statement No. 13:

Statement 13: Trust

A government-and-professional led program to build trust on AI usage in clinical practice based on evidence should be established

Trust is defined as belief or confidence in the reliability, credibility and integrity of a person, system or technology which leads to usage or action (Mayer et al. 1995)

Engagement of users is a key step for strengthening respect of persons and building public trust.



Our Solution: Embrace a New Paradigm in AI ...

Old: Bottom-up Evolution

- Mind Is What Brain Does
- Mind Comes from Evolution
- Development without Design
- Computer-aided Intelligence
- Tuning Is Learning



New: Top-Down Design

- Mind Is Not Brain
- Mind Comes from Design
- Production after Design
- Self-Intelligence
- Tuning Is Not Learning

New Outlook of Body-Brain-Mind

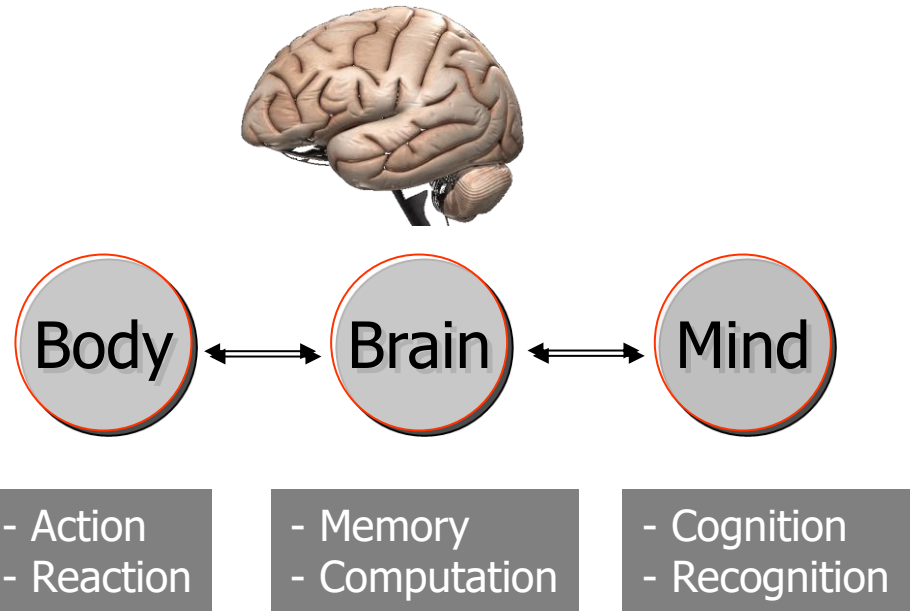

Last Frontier in Science: “Science of Mind”
How to design machine’s mind?

Coarse Minds
知识

Subtle Minds
意识



Deep Minds
心识



• Soul
• Life

What is body?

- A body is a motion system which could undertake action and reaction.

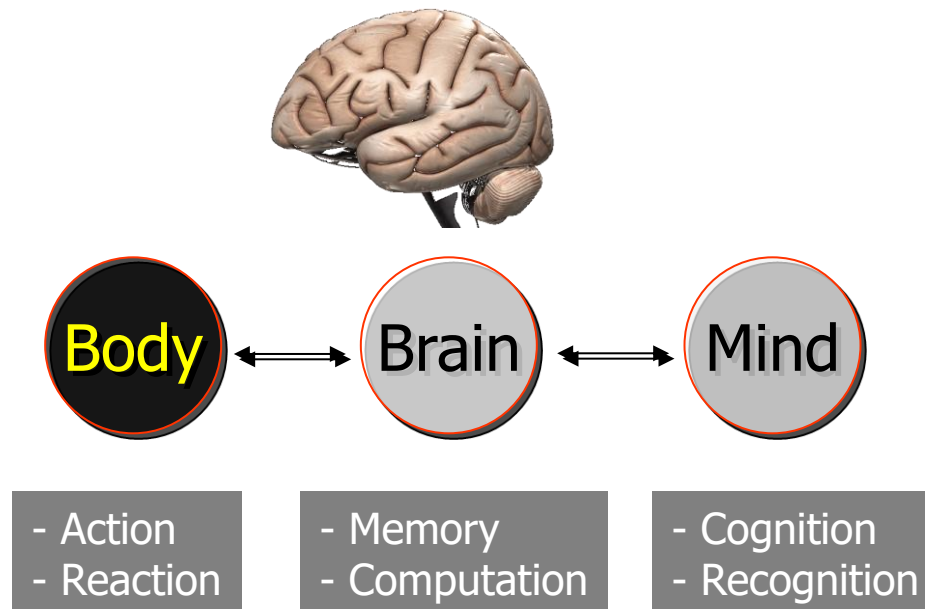

What is brain?

- A brain is a computing system which could undertake computation and memorization.

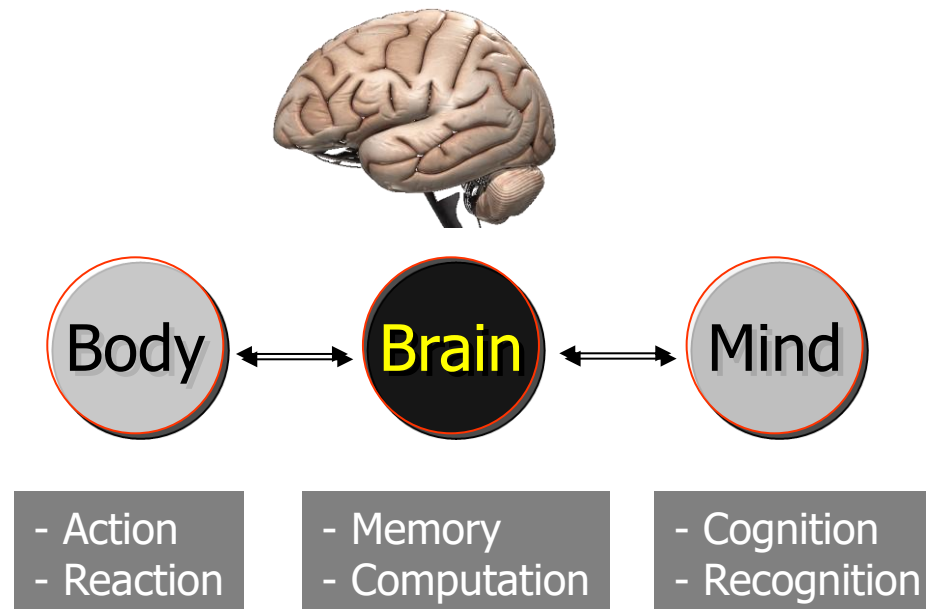

What is mind?

- A mind is a knowledge system which could undertake cognition and recognition.

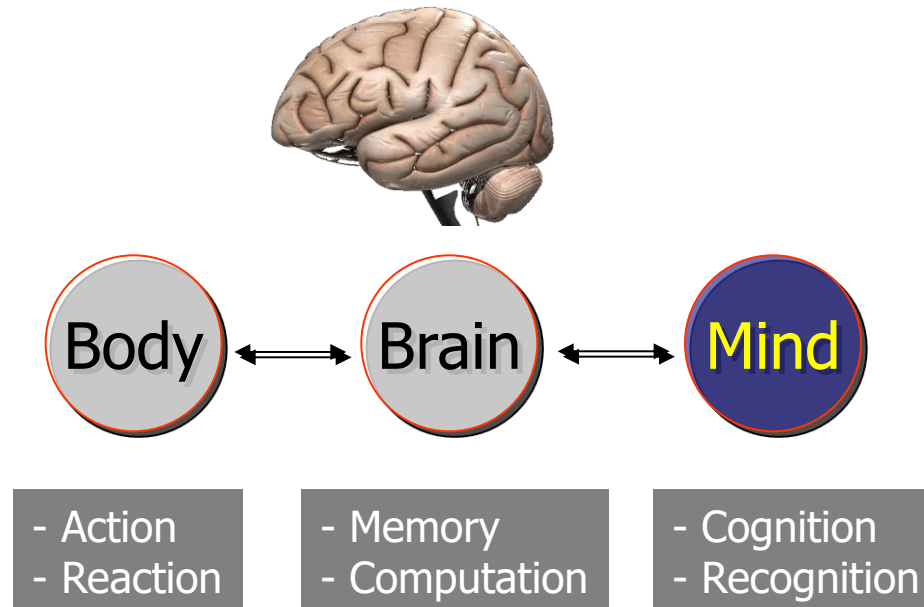

Astonishing Truth Between Brain and Mind ...

- Energy -> Signal -> Data -> Big Data -> Big Intelligence

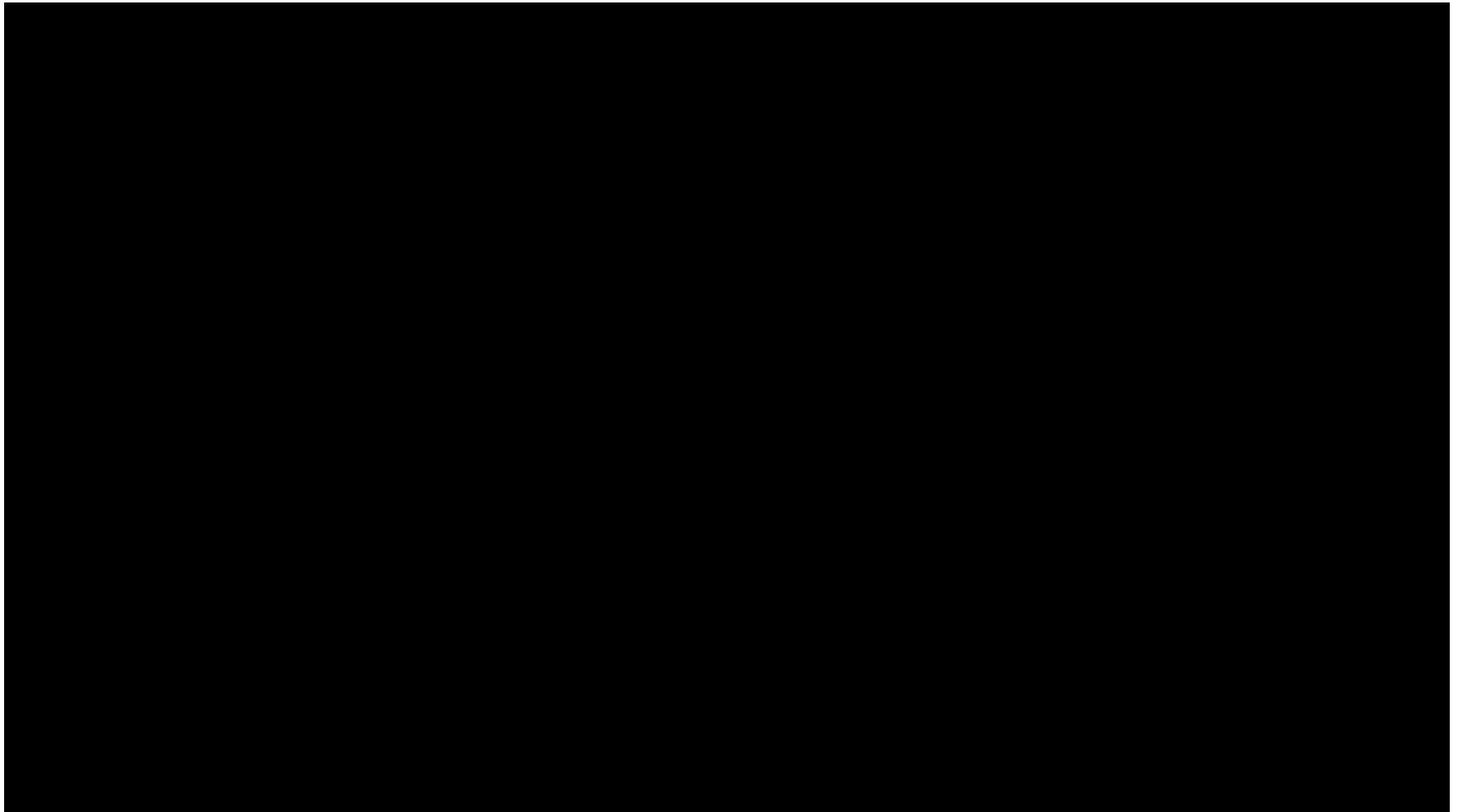

Astonishing Truths Between Brain and Mind

...

- Life never dies
- Life reincarnates
- One body has one brain
- One brain could house different minds

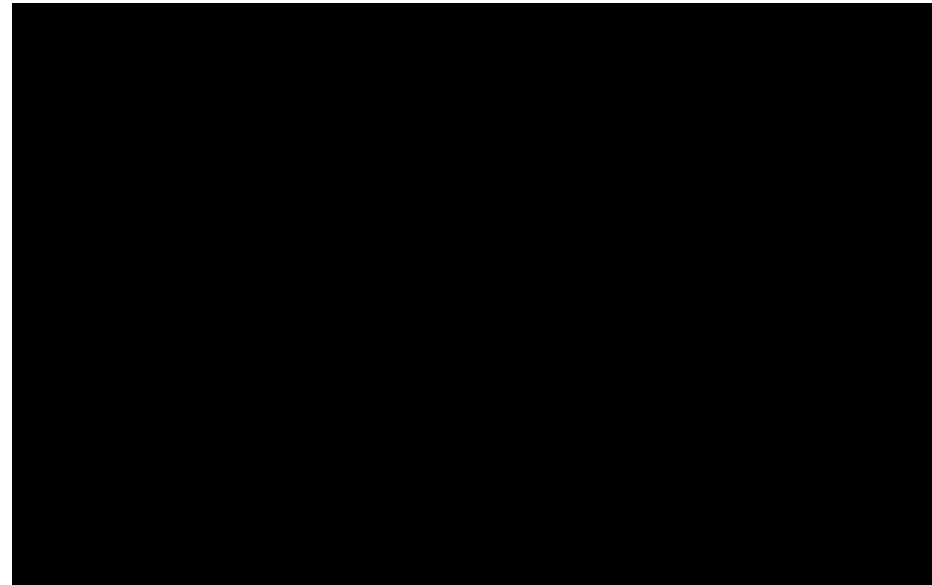

Astonishing Truths Between Brain and Mind

...

- Life never dies
- Life reincarnates
- One body has one brain
- One brain could house different minds
- **One mind has multiple settings**



How to make machines to learn?

How to design educable robots or machines?

- In my book published in 2003, I said that the necessary condition for a machine to be able to learn is to be educable.
- How much promise remains for entrepreneurs? Plenty, Gates insisted during a tour of several top universities in 2004. In a stop at MIT, a student asked Gates if another tech company could ever match Microsoft's success. **“If you invent a breakthrough in artificial intelligence so machines can learn,”** he responded, **“that is worth 10 Microsofts.”**

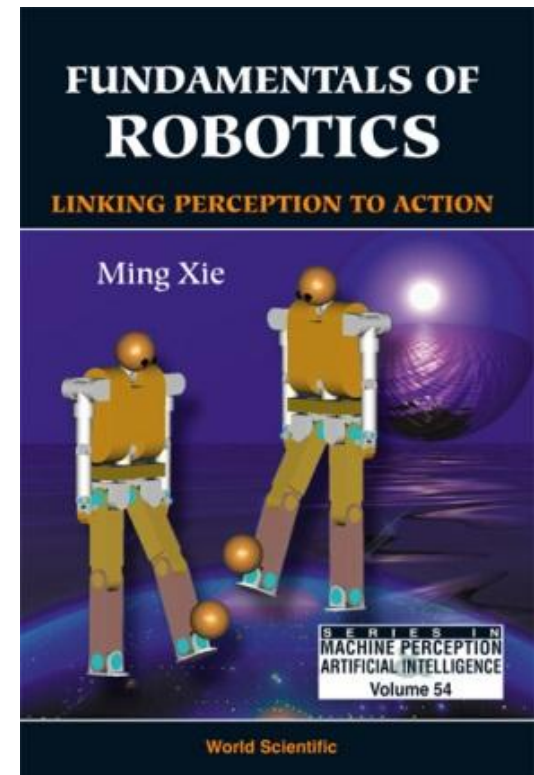

What should be the true foundation of AI?

- The foundation of Artificial Intelligence should be **machine's self-intelligence**, which aims at discovering and implementing the principles behind the transformations from signals to cognitive states of knowing the meanings inside the signals.

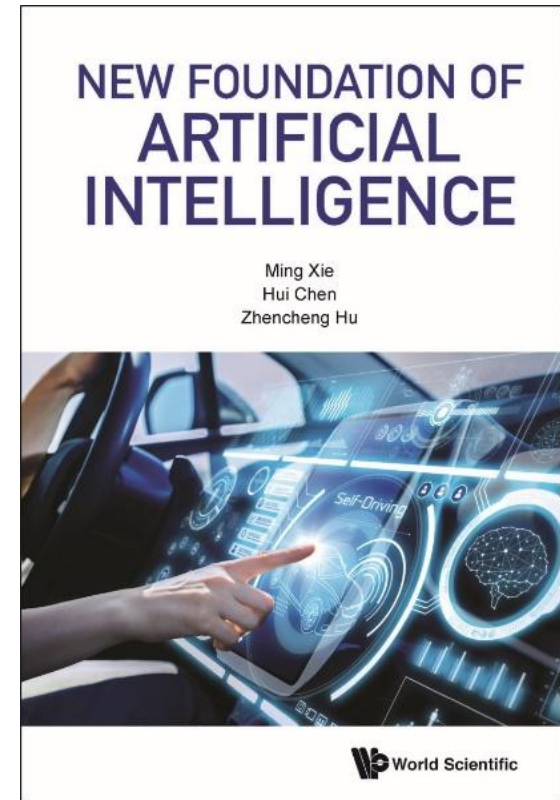

True Foundation of Artificial Intelligence

- One Tool
- Two Worlds
- Three Intelligences
- Four Pillars

- Signal to Knowledge 受蕴
- Knowledge to Knowledge 想蕴
- Knowledge to Signal 行蕴

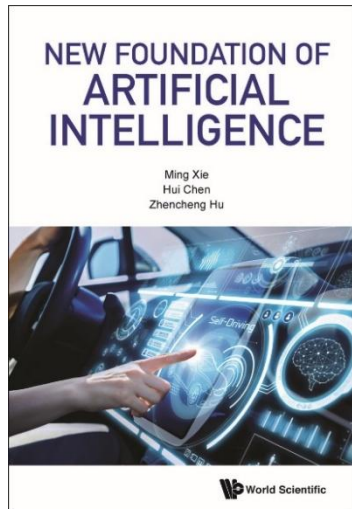
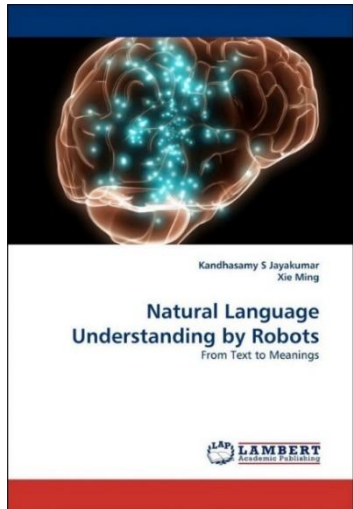
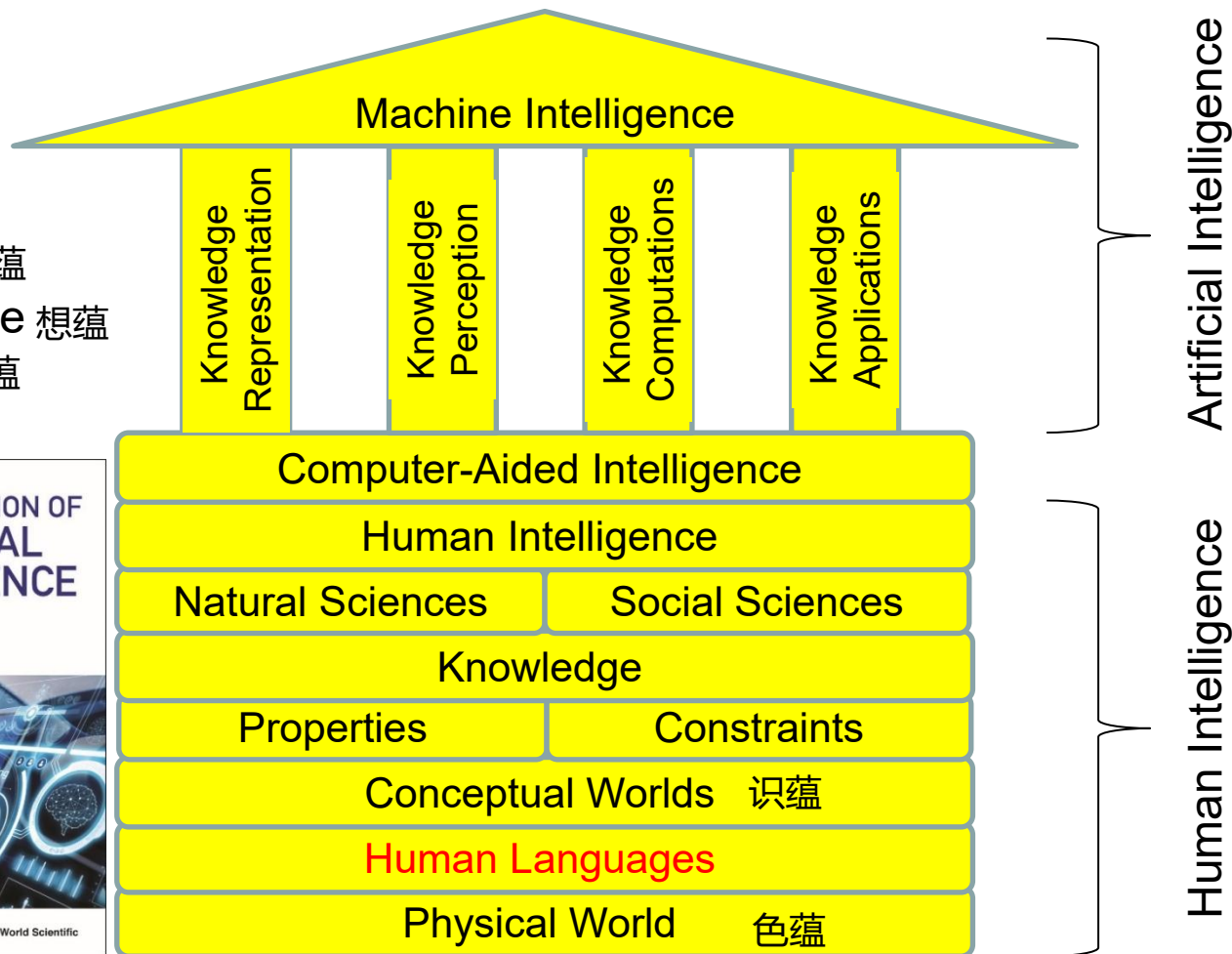

New History of Artificial Intelligence

- AI 1.0: Machine Thinking
- AI 2.0: Machine Learning
- AI 3.0: Machine's Self-Intelligence

1943-1956 **AI 1.0**
 John McCarthy
 Marvin Minsky
 Nathaniel Rochester
 Claude Shannon
 1956 Dartmouth Workshop

1992-2000 **AI 2.0**
 John Weng
 James McCelland
 Alex Pentland
 2000 MSU Workshop

AI 3.0
 2003-2009
 Ming Xie
 2009 IJHR Paper

2010

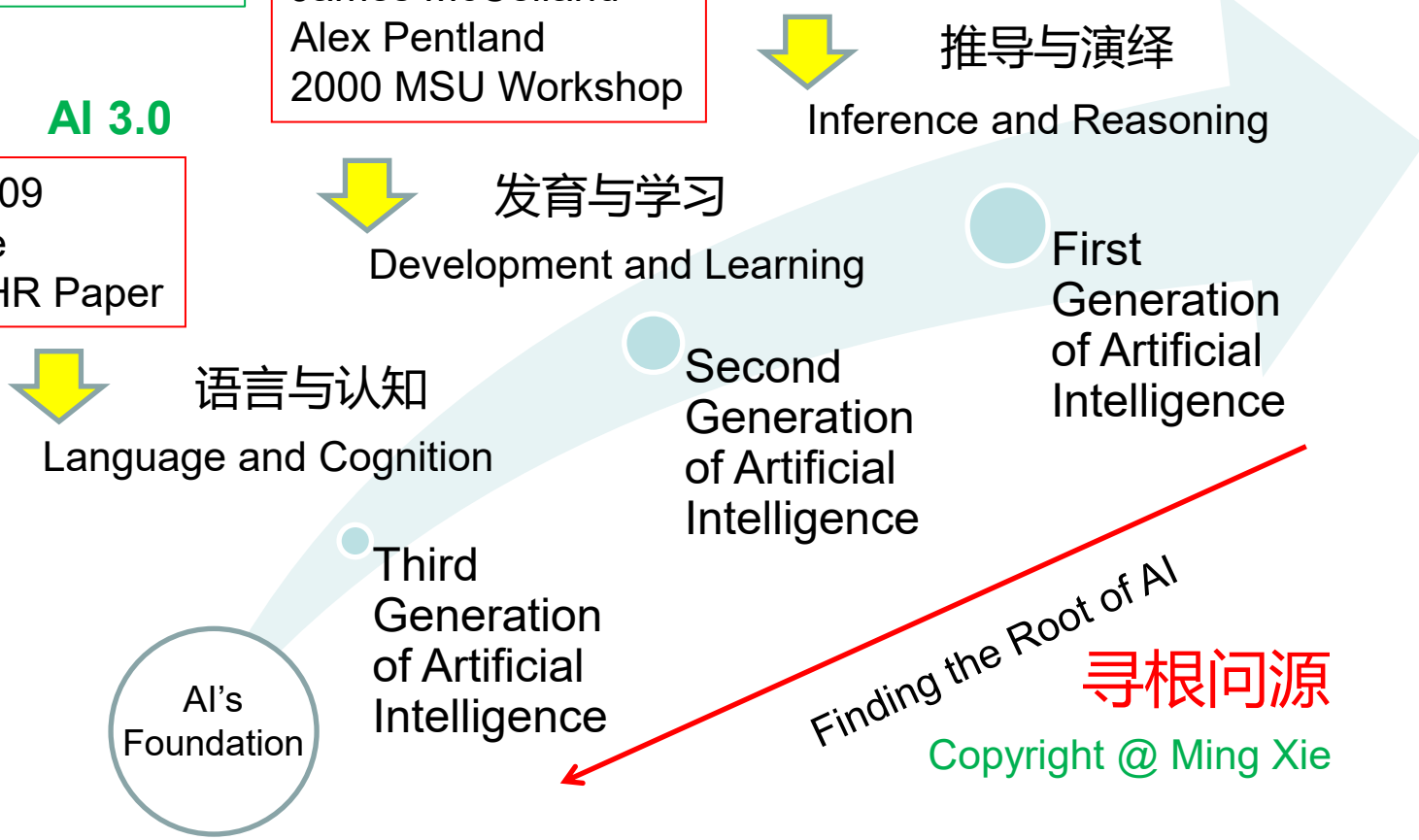
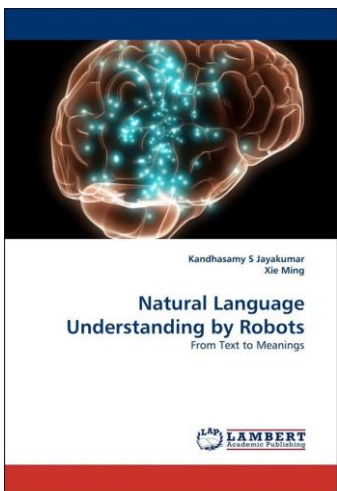

New Definition of Intelligence ...

- Intelligence is the mental ability of transforming sensory signals to knowledge, knowledge to knowledge, and knowledge to motor signals.
- Intelligence is inversely proportional to the time taken for the accomplishment of any given task.

$$Intelligence = \frac{1}{Time}$$

New Definition of Machine Intelligence ...

Definition of AI 3.0

- Artificial intelligence refers to **any machine's mental capabilities of acquiring, representing, memorizing, transforming, transferring, and applying knowledge about truths and skills.**

Learning = Representation + Memorization

Knowledge = Statics (Truths) + Dynamics (Skills)

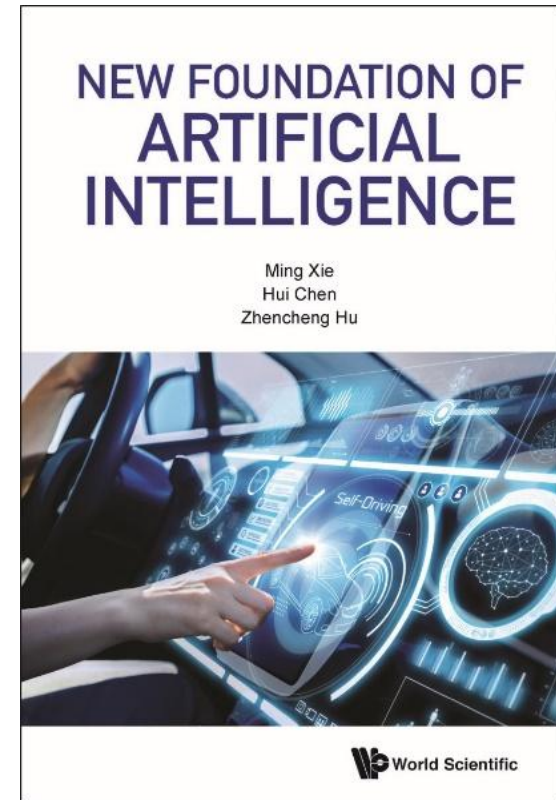

New Way of Evaluating the Levels of Intelligence in AI Systems, AI Machines, or AI Products ...

- My suggestion is to advocate the following better version of test:
- Define intelligence as being a metrics which is inversely proportional to the time taken by an intelligent entity to complete a given task such as writing, reading, talking, making, playing, etc.

$$\text{Intelligence} = \frac{1}{\text{Time Taken for a Task}}$$

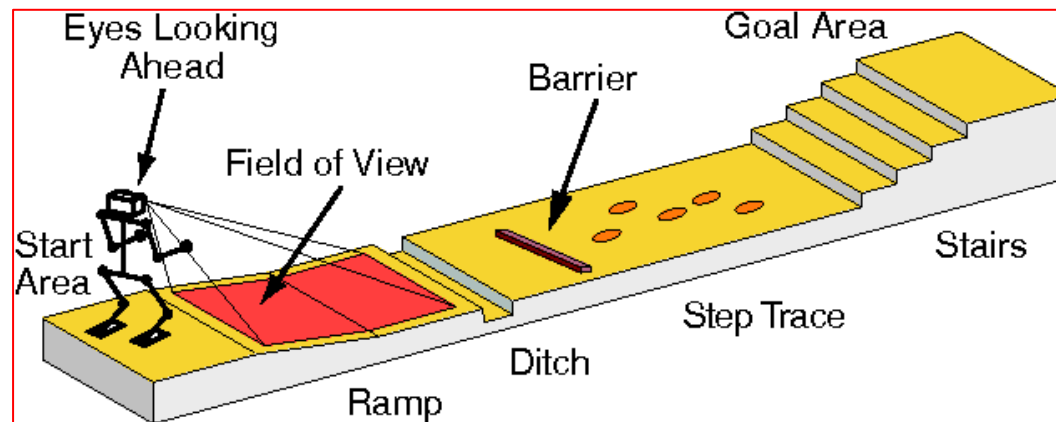

New Blueprint of Knowledgeable and Skillful Machines or Systems ...

AI's New Paradigm: Signal \rightarrow Knowledge \rightarrow Knowledge \rightarrow Signal

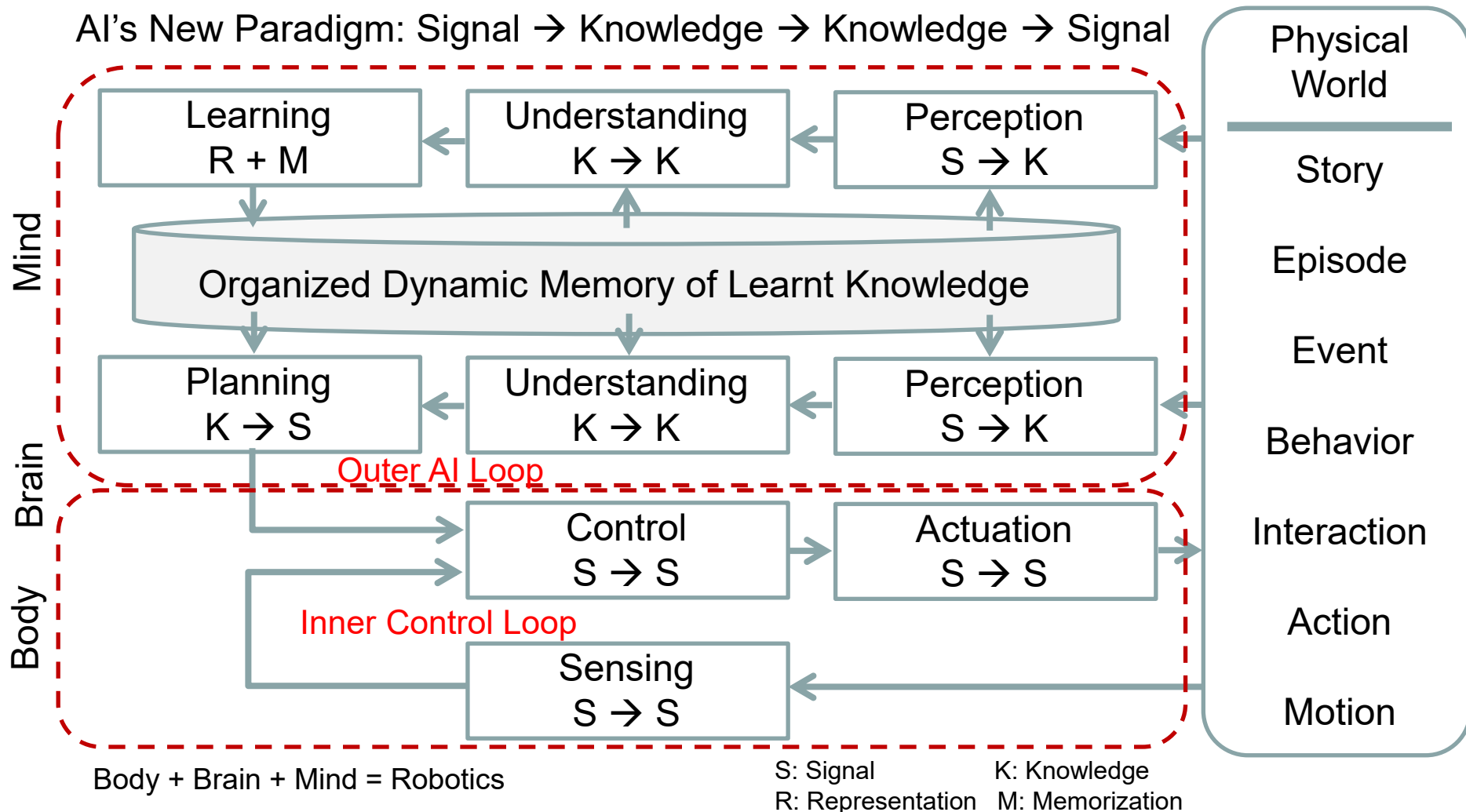

(Learning, Teaching) <o> (Research, Innovation) <o> (Leadership, Service)

Example of Knowledgeable and Skillful Humanoid Robot ...

- Body
- Brain
- Mind



Remaining
Challenge

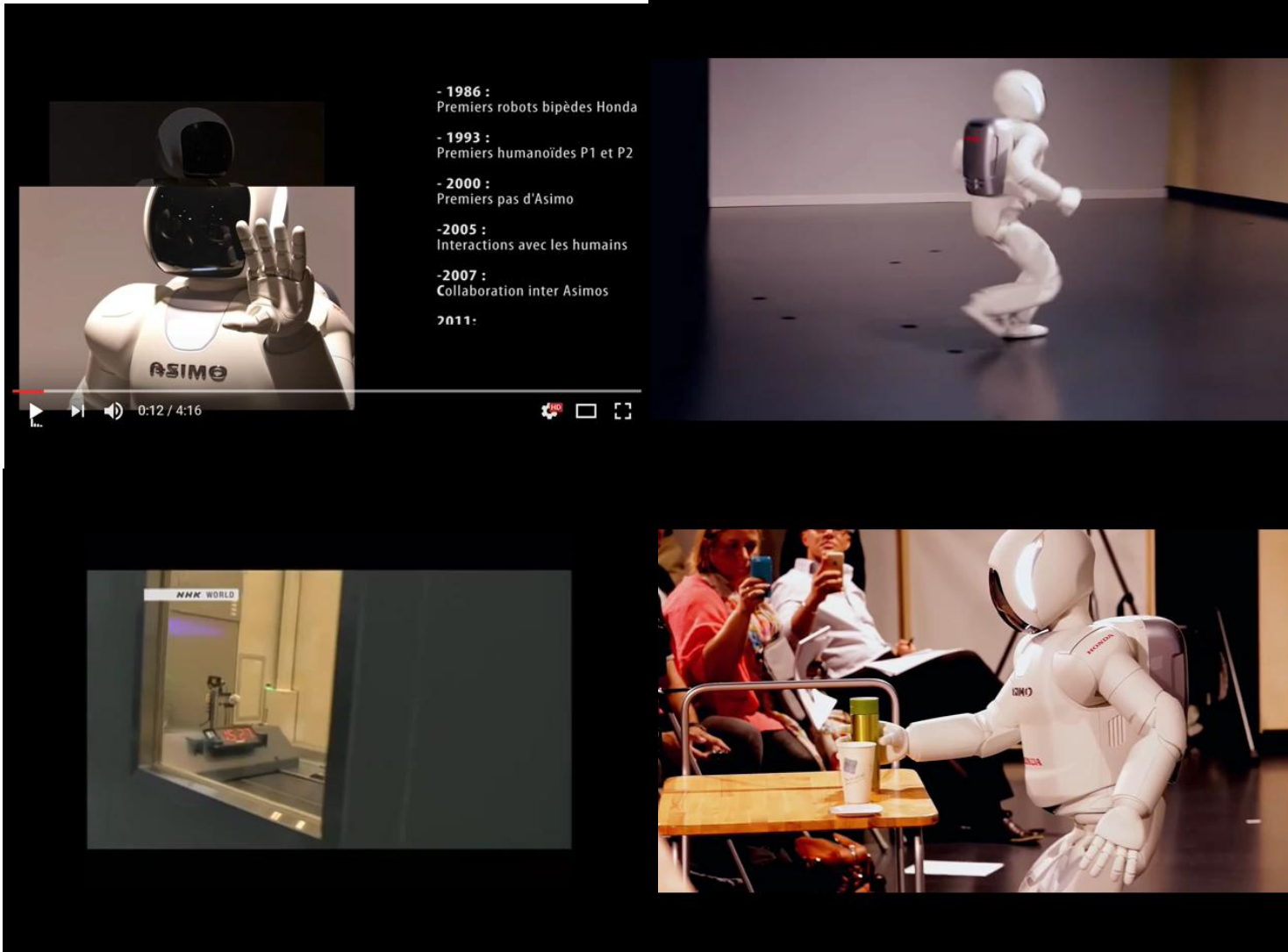

More examples ...

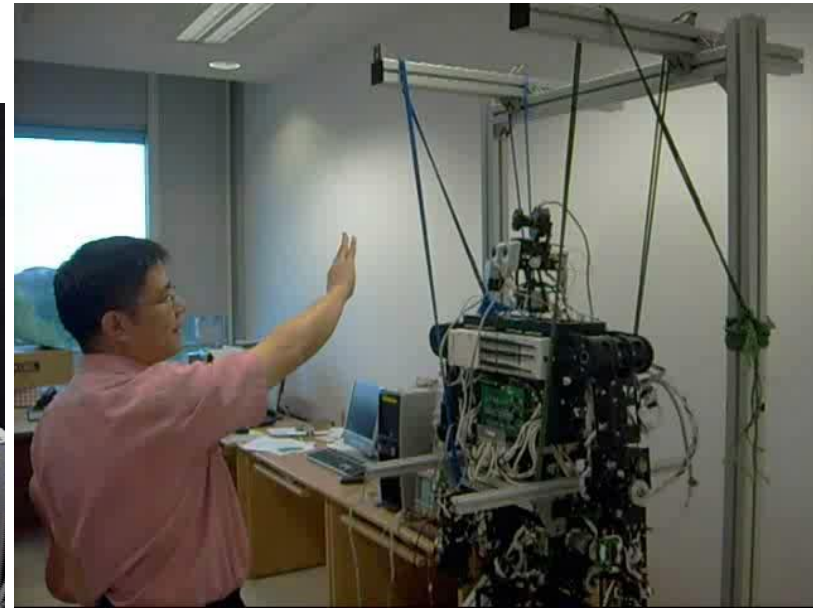

With the Rise of Robotics ...

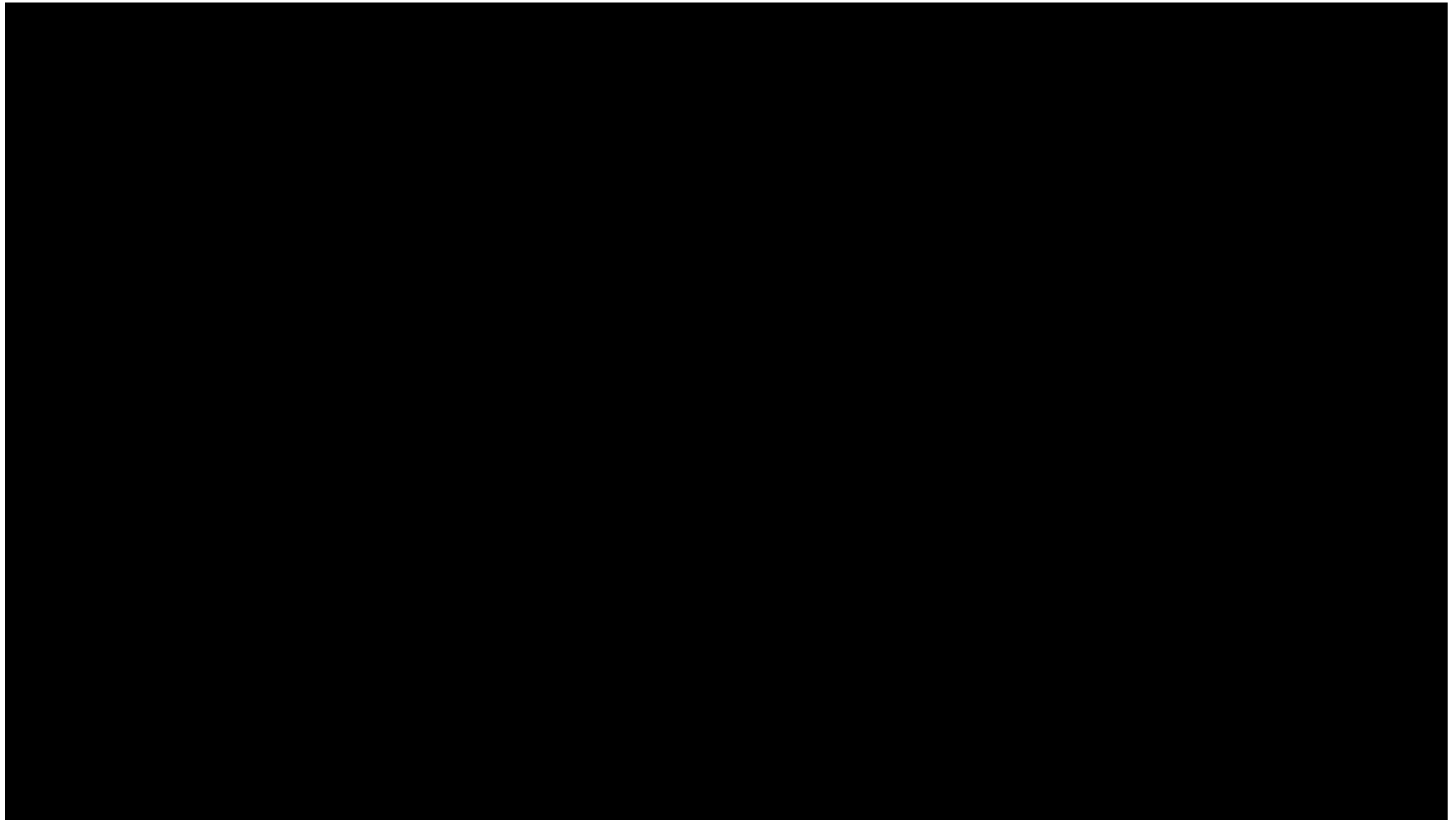

New Force of AI: Robotics Will Drive the Development of AI ...

- Talking
- Seeing
- Reading
- Thinking
- Composing

Task Space

Joint Space

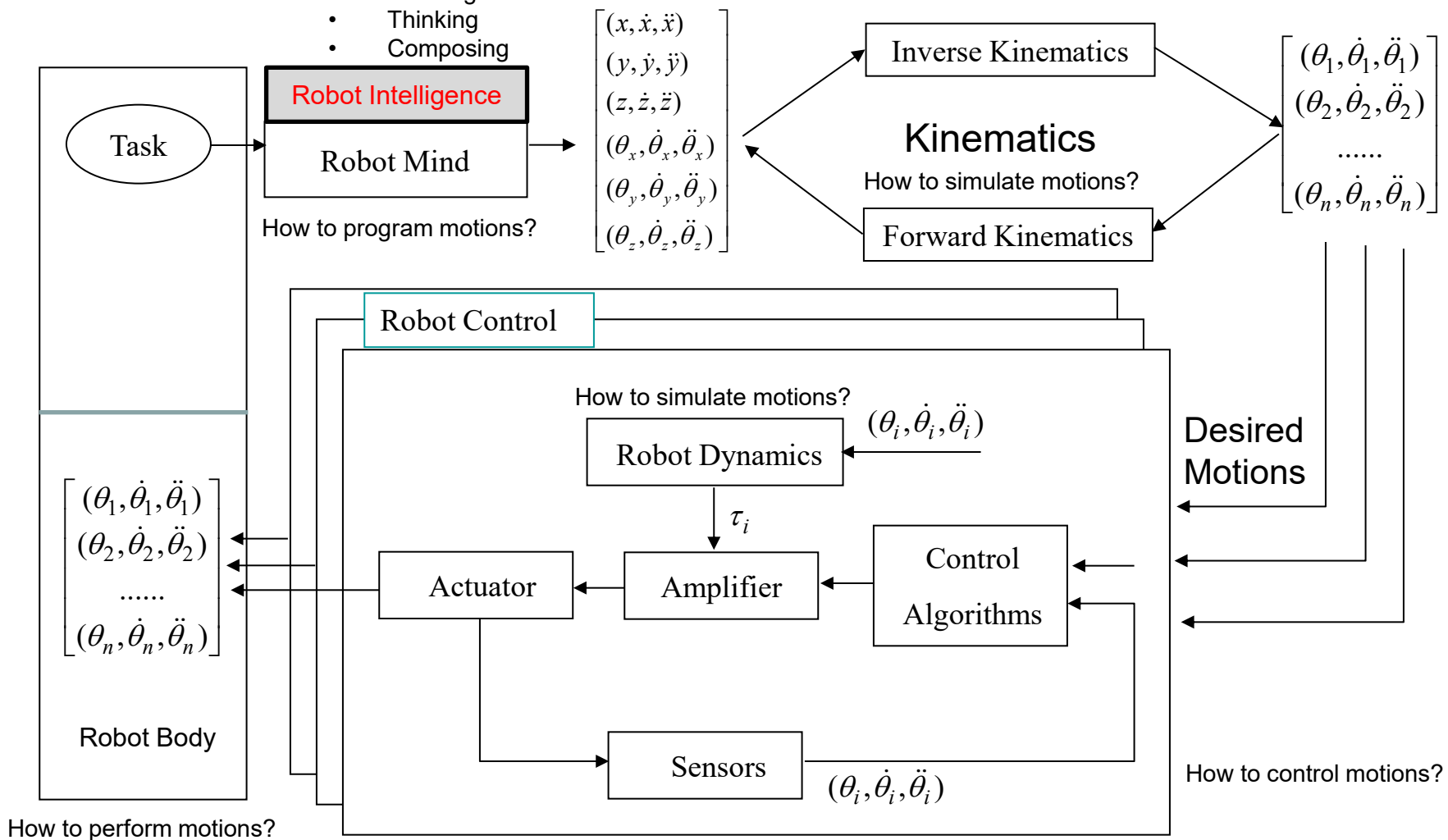

New Book of AI ...

February 2021

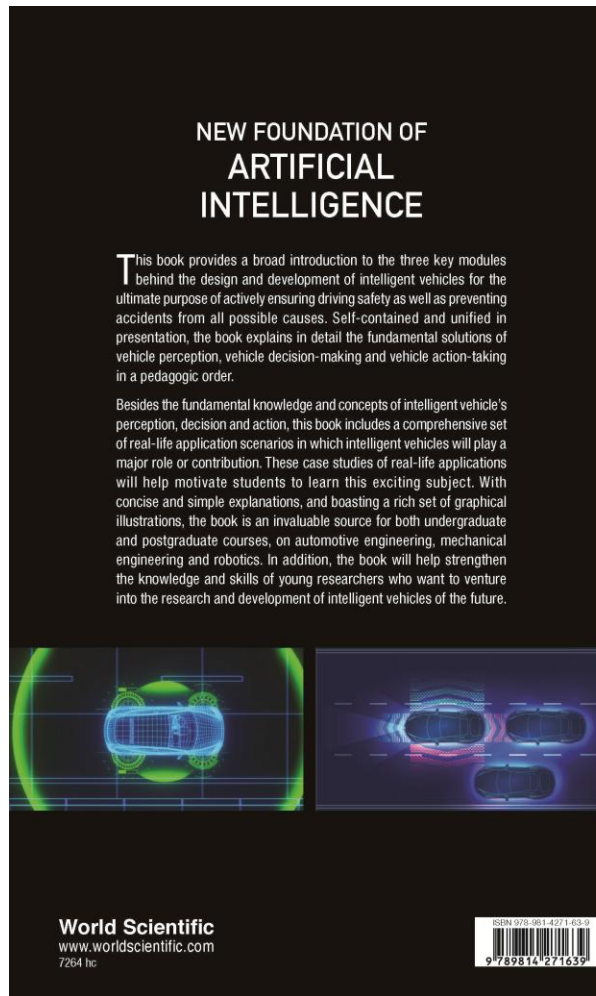

NEW FOUNDATION OF ARTIFICIAL INTELLIGENCE

NEW FOUNDATION OF ARTIFICIAL INTELLIGENCE

Ming Xie
Hui Chen
Zhencheng Hu



Xie
Chen
Hu



World Scientific

Outline of Lecture 1

- AI 1.0: Machine Thinking
- AI 2.0: Machine Learning
- AI 3.0: Machine Self-Intelligence
- Overview of Machine's Visual Intelligence

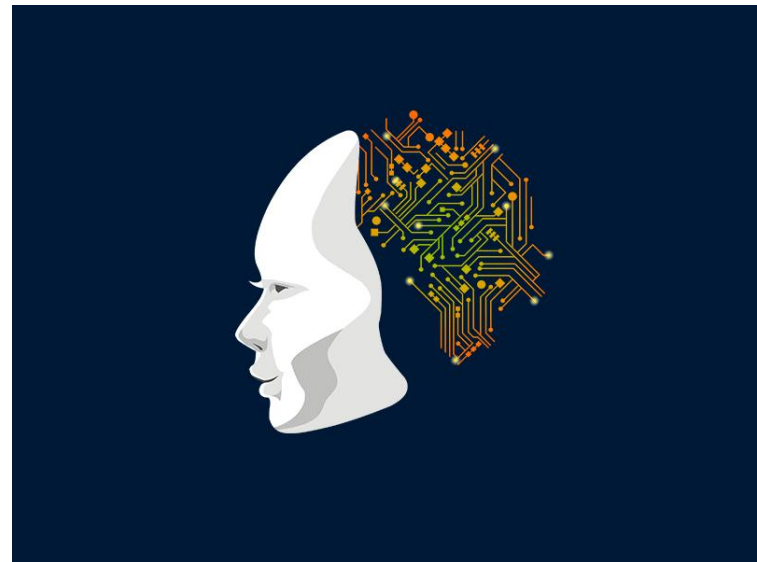

How to design a machine's mind?

- What are inputs?
- What are the inner processes or transformations?
- What are outputs?

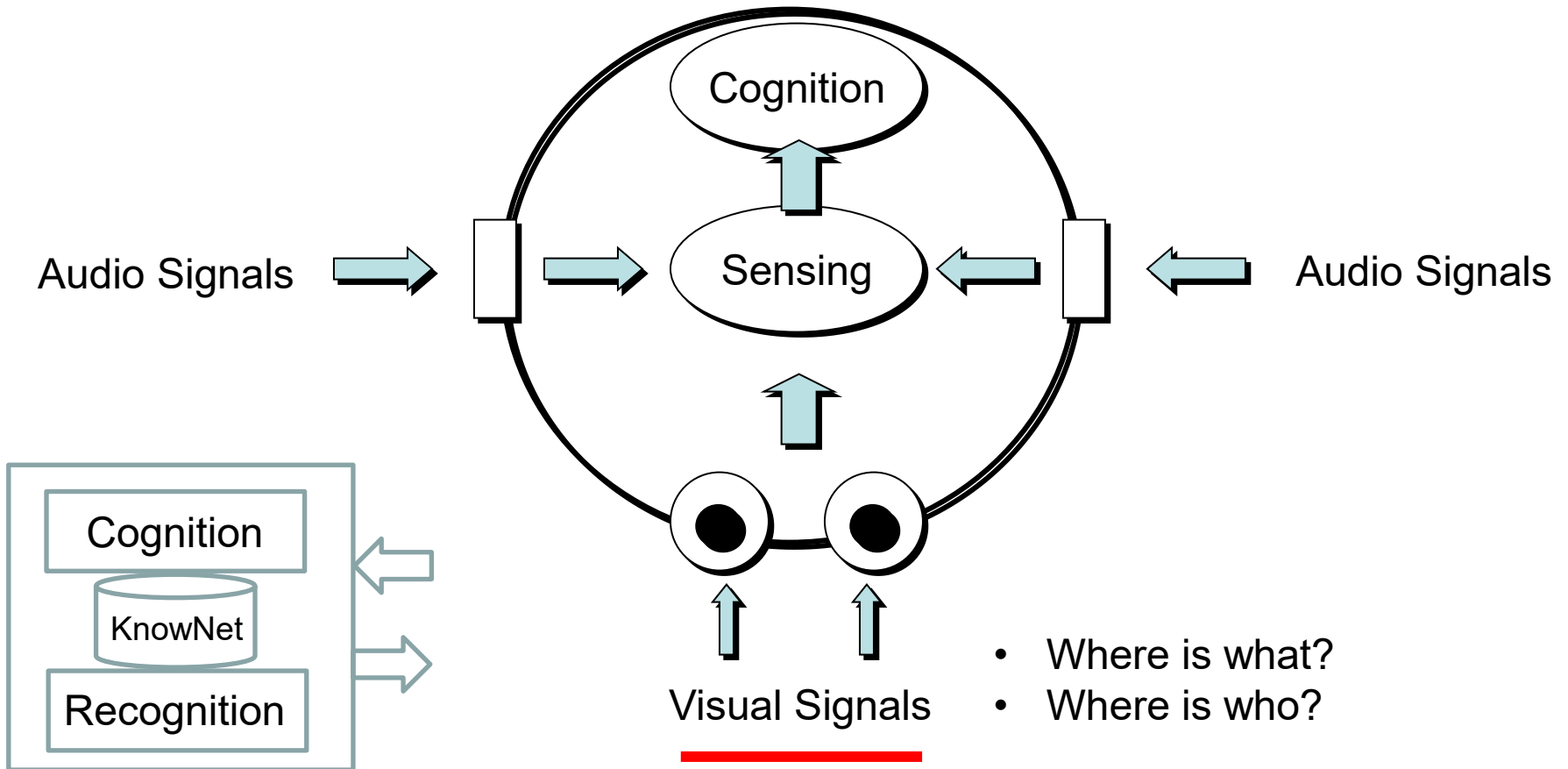

Truth about Input to AI Systems

- We are living inside an ocean of signals which could be transformed into knowledge-flows by our minds.



Visual Intelligence and Its Input

- Visual intelligence will enable machine to achieve the transformations from visual signals to cognitive states of knowing the meanings behind the visual signals:

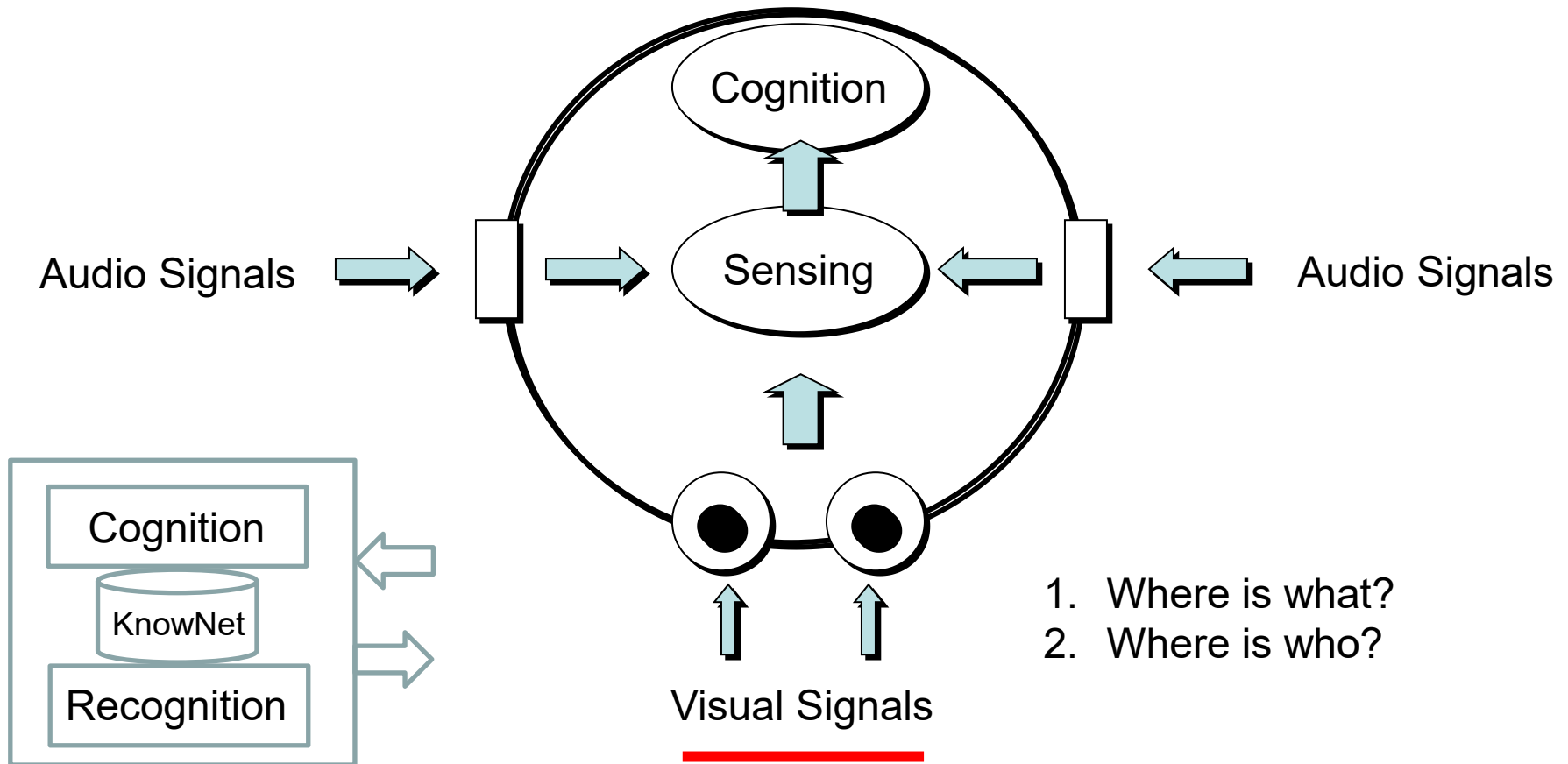

Importance of Visual Intelligence

Among all the signals to AI systems, visual signals occupy the No. 1 position!

“百闻不如一见”， - 孔子 (Confucius)

- A picture is worth more than a thousand of words.
- Colorless has no difference than colorfulness.

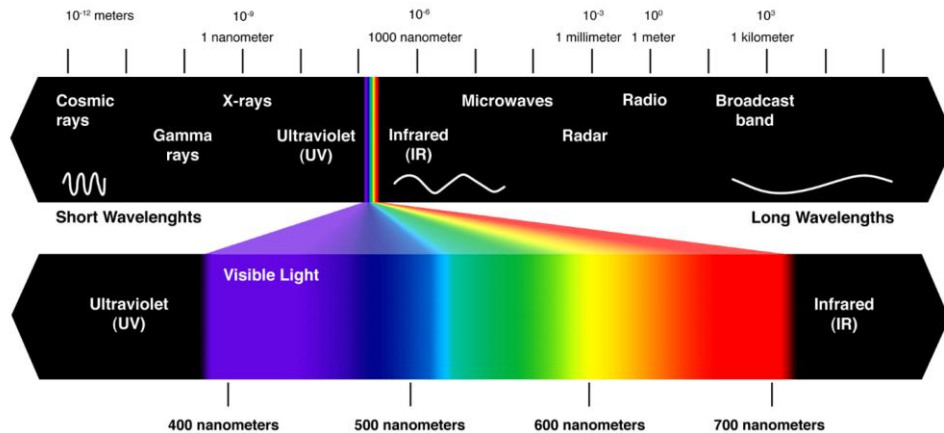

- Colorfulness has no difference than colorless.

One Look Is Worth A Thousand Words--

One look at our line of Republic, Firestone, Miller and United States tires can tell you more than a hundred personal letters or advertisements.

WE WILL PROVE THEIR VALUE BEFORE YOU INVEST ONE DOLLAR IN THEM.

Ever consider buying Supplies from a catalog?

What's the use! Call and see what you are buying. One look at our display of automobile and motorcycle accessories will convince you of the fact.

THAT WE HAVE EVERYTHING FOR THE AUTO

Piqua Auto Supply House
133 N. Main St.—Piqua, O.

General Framework of Visual Intelligence

- Signal → Knowledge → Knowledge → Signal
- Action
- Imagination

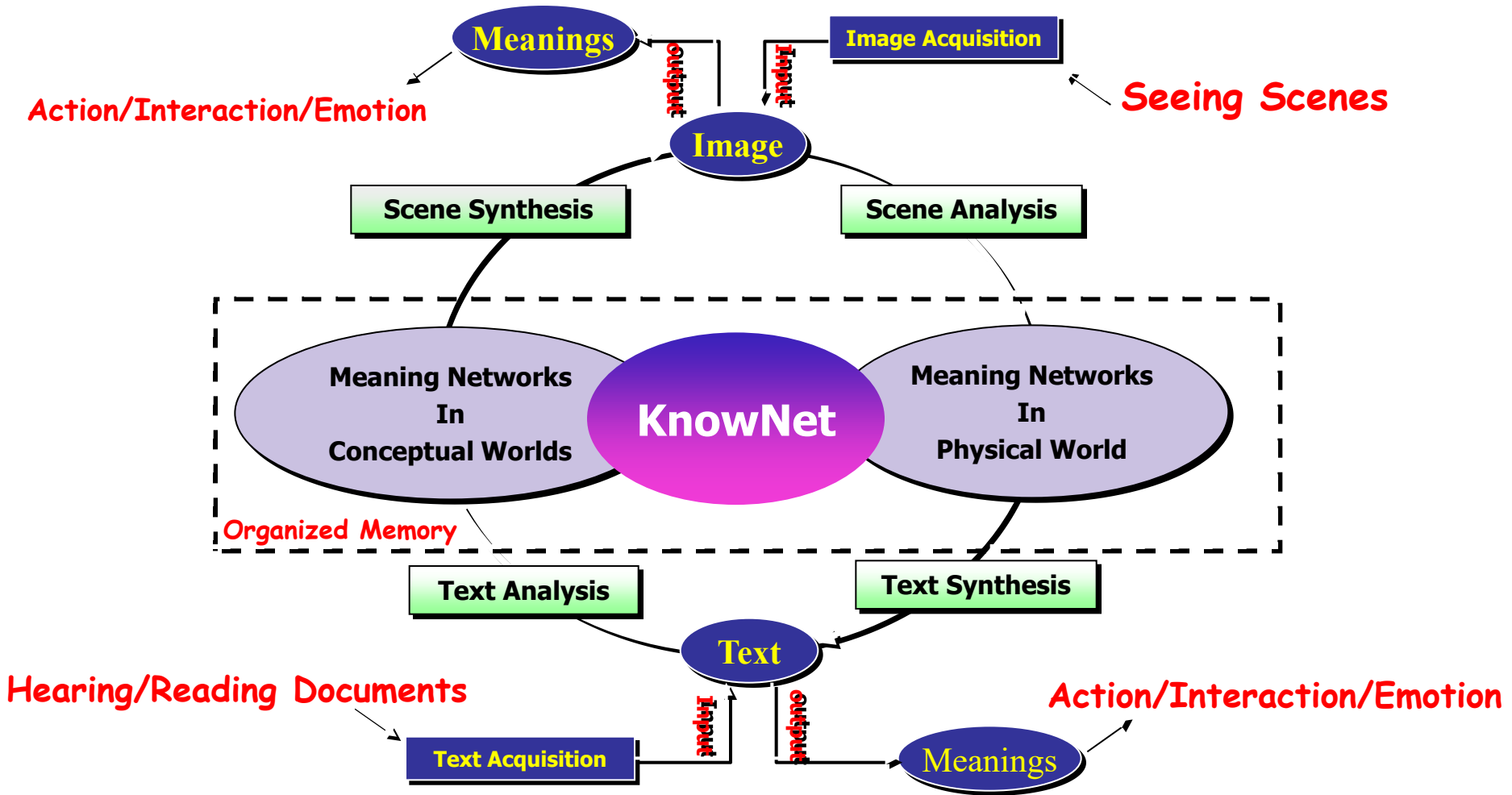

A Large Knowledge Model for Visual Intelligence ...

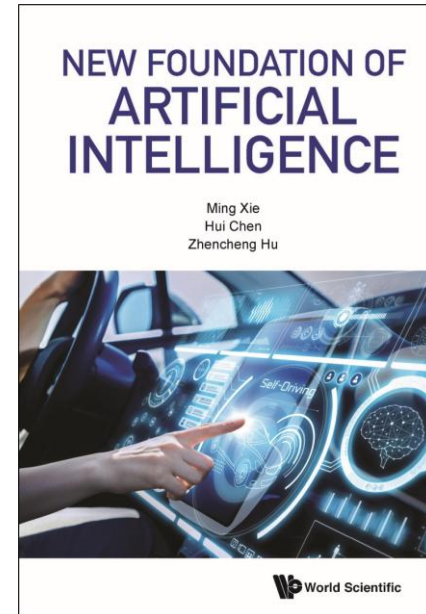
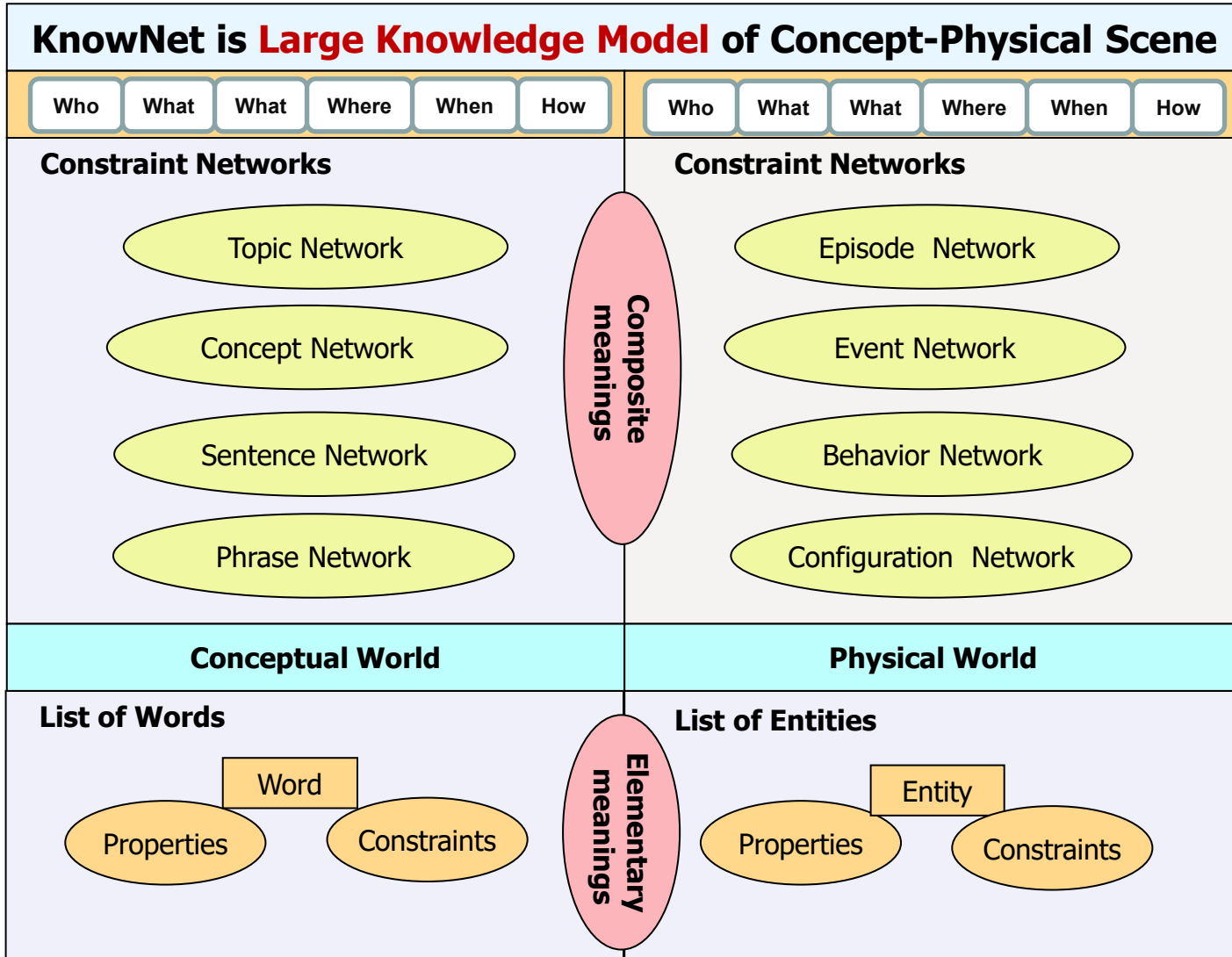

Key Focus: How to transform visual signals into elementary meanings? Solution consists of ...

- Step 1: Transform visual signals into elementary meanings in the physical world.
- Step 2: Transform elementary meanings in the physical world into elementary meanings in a conceptual world.

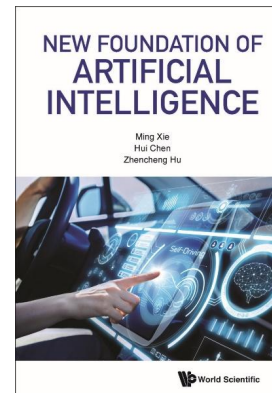
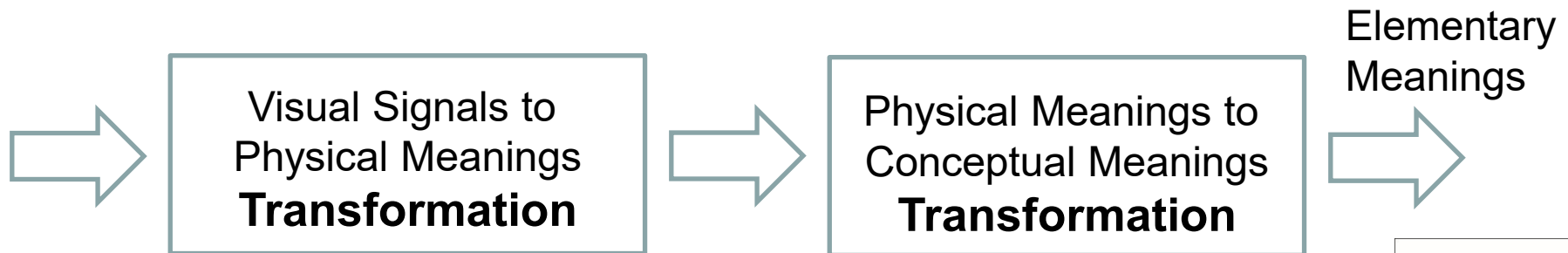

How to transform physical meanings into conceptual meanings?

(output = symbol with belief)

$A(X)$: *SoftPlus, SoftMax, Sigmoid, etc*

- Method 1: To use artificial neural networks as predictors ...



Feature Vector at Layer 0:

$$\text{Input} = F_0 = \{f_{0,i}, i = 1, 2, \dots\}$$

Feature Vector at Layer 1:

$$F_1 = A(W_0 \times F_0 + B_0)$$

Feature Vector at Layer k:

$$F_k = A(W_{k-1} \times F_{k-1} + B_{k-1})$$

.....

Feature Vector at Layer n:

$$F_n = A(W_{n-1} \times F_{n-1} + B_{n-1})$$

Conceptual Meanings at Output:

$$\text{Belief} = \{[\text{belief}_i, \text{possibility}_i(F_n)], i = 1, 2, \dots, m\}$$

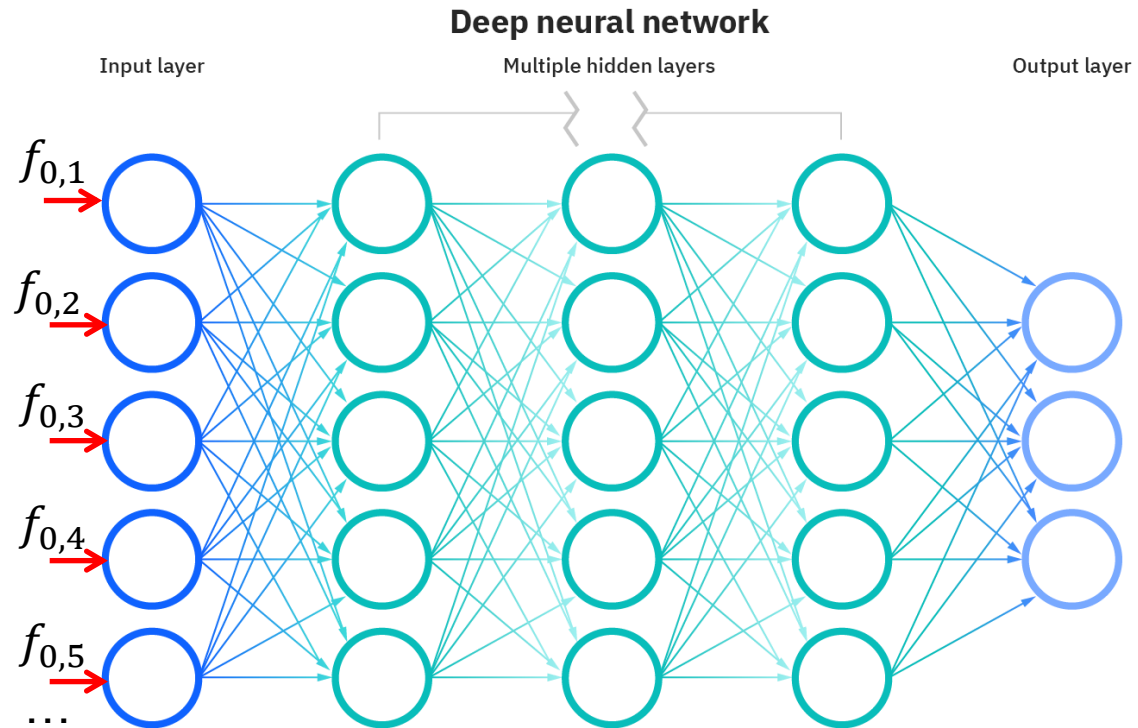

MIMO

Popular Activation Functions:

- SoftPlus Function:
$$\left\{ \begin{array}{l} X = \{x_i, i = 1, 2, \dots, n\} \\ A(X) = \{\ln(1 + e^{x_i}), i = 1, 2, \dots, n\} \end{array} \right.$$

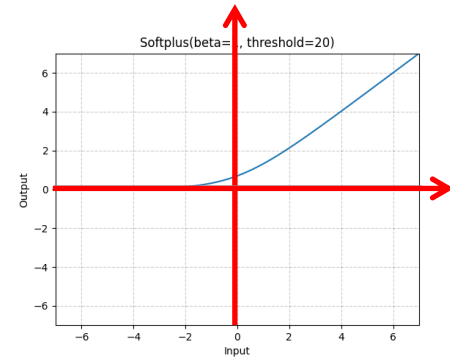

- SoftMax Function:
$$\left\{ \begin{array}{l} X = \{x_i, i = 1, 2, \dots, n\} \\ A(X) = \left\{ \frac{e^{x_i}}{\sum_{i=1}^n e^{x_i}}, i = 1, 2, \dots, n \right\} \end{array} \right.$$

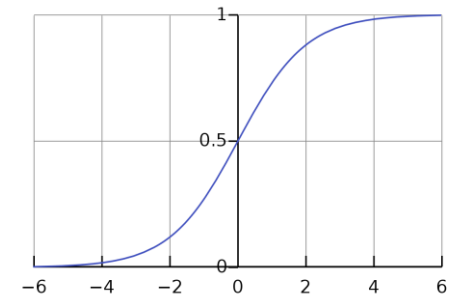

- Sigmoid Function:
$$\left\{ \begin{array}{l} X = \{x_i, i = 1, 2, \dots, n\} \\ A(X) = \left\{ \frac{1}{1 + e^{-x_i}}, i = 1, 2, \dots, n \right\} \end{array} \right.$$

- ReLU (Rectified Linear Unit):
$$\left\{ \begin{array}{l} X = \{x_i, i = 1, 2, \dots, n\} \\ A(X) = \{\max(0, x_i), i = 1, 2, \dots, n\} \end{array} \right.$$

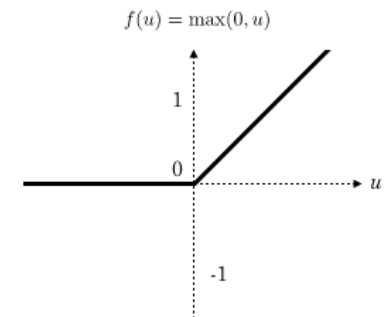

How to transform physical meanings into conceptual meanings? (output = symbol with belief)

- Method 2: To use RCE neural networks as match-makers ... ✓

Input Layer of Single Feature Vector:

$$\text{Input} = F_0 = \{f_{0,i}, i = 1, 2, \dots\}$$

Middle Layer of Prototype Vectors:

$$F = \{F_i = (\vec{\mu}, \vec{\sigma}), i = 1, 2, \dots, n\}$$

Output Layer of Single Symbol:

$$\text{Belief with Possibility} = \max\{\text{possibility}(F_0, F_i), i = 1, 2, \dots, n\}$$

One Unit of Restricted-Coulomb-Energy Neural Network

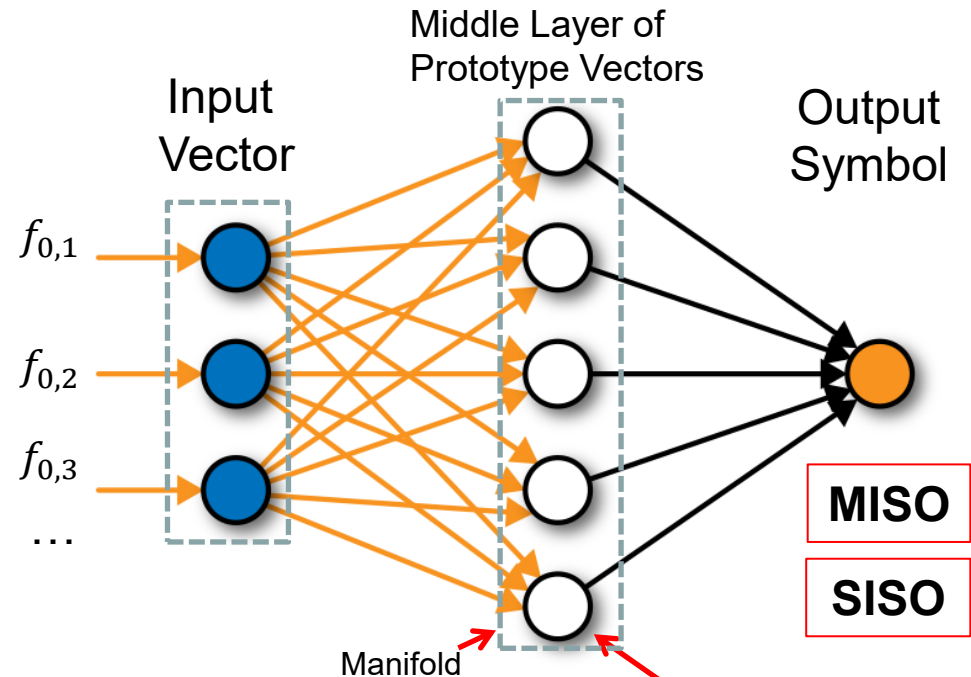

What is a possibility function?

- Any sensory data could trigger a mental belief with a certain level of possibility.
- A possibility function is associated with a belief generated by a sensory data.
- A possibility function varies from 0 to 1.
- A popular possibility function is:

$$P(x) = e^{-\frac{1}{2}\left(\frac{x-\mu}{\sigma}\right)^2}$$

$$f(x) = ae^{-\frac{(x-b)^2}{2c^2}}$$

a = height of the curve's peak
b = the position of the center of the peak
c = the standard deviation
f(x) = function of *x*
e = Euler's number

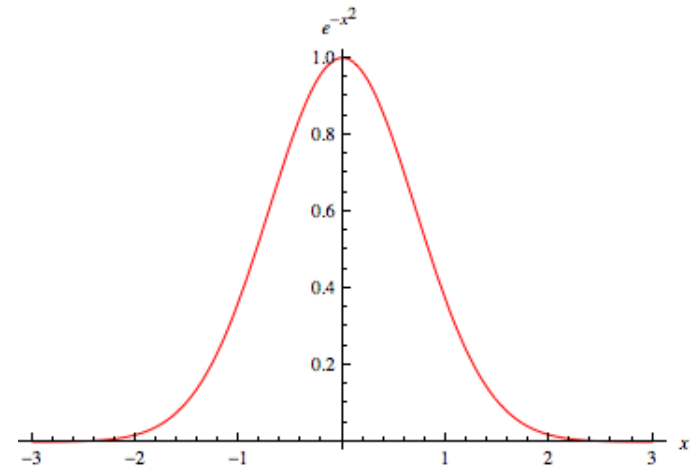

An Important Property of Ideal Systems:

- MIMO = Sum of SISOs
- RCE NN is an ideal system!

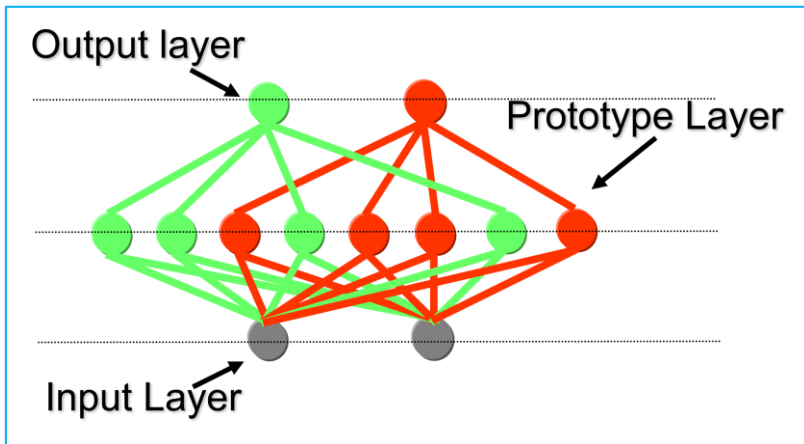

MIMO = Sum of MISOs

MIMO = Sum of SISOs

≡

Incremental Learning

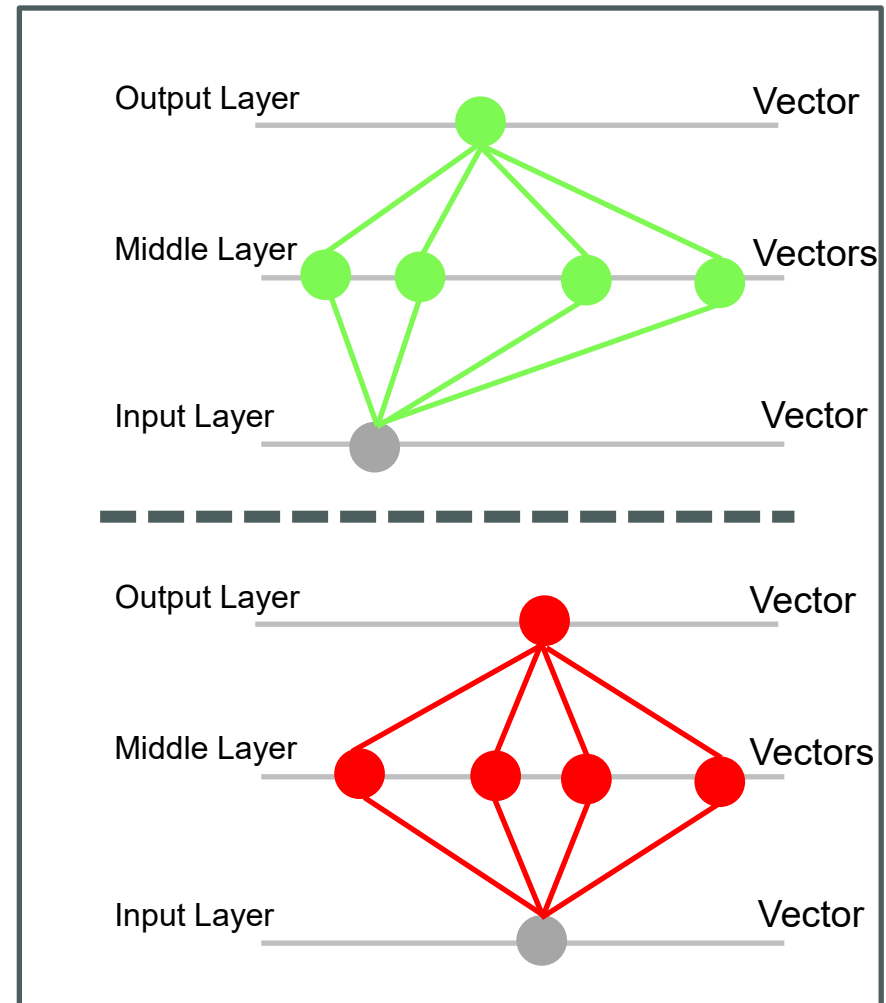

Summary of Lecture 1

- AI 1.0: Machine Thinking
- AI 2.0: Machine Learning
- AI 3.0: Machine Self-Intelligence
- Overview of Machine's Visual Intelligence

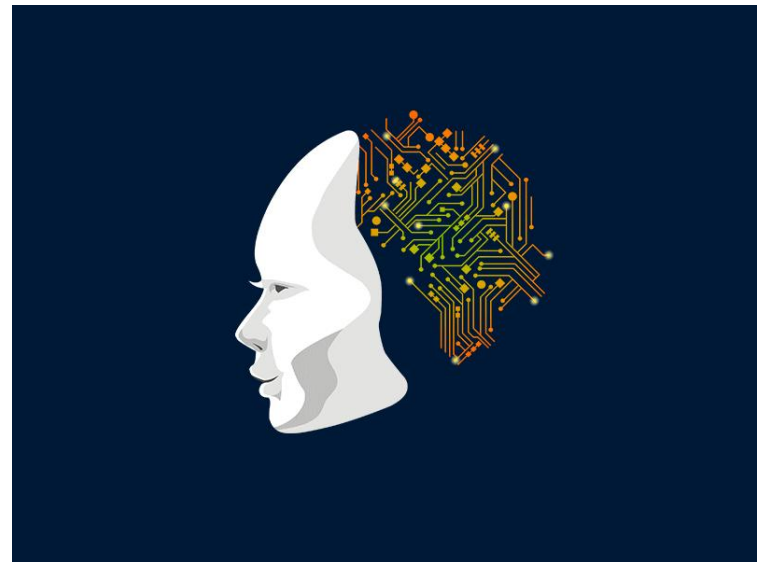

Outline of Module 1

- Lecture 1:
 - True Foundation of AI Systems
- Lecture 2:
 - Input to AI Systems
- Lecture 3:
 - Output from AI Systems





**NANYANG
TECHNOLOGICAL
UNIVERSITY**

School of Mechanical & Aerospace Engineering

Design, Machine, Control, Intelligence

Lecture 2 of Module 1

AI 3.0

MA4829 Machine Intelligence

Input to AI Systems



XIE Ming, PhD (France)

<http://personal.ntu.edu.sg/mmxie>

“We are living inside an ocean of signals”



What is a system with intelligence inside?

(Learning, Teaching) <o> (Research, Innovation) <o> (Leadership, Service)

Outline of Lecture 2

- Physical World as Input
- Signal as Input
- Knowledge as Input

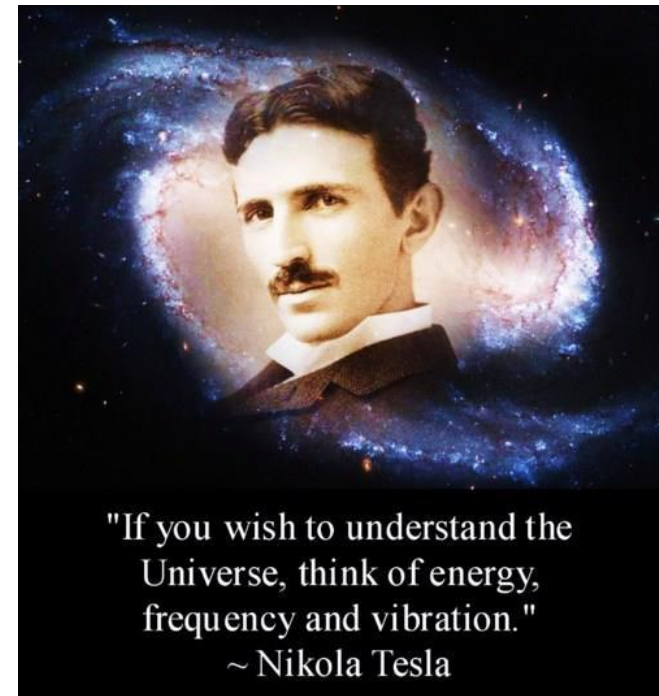
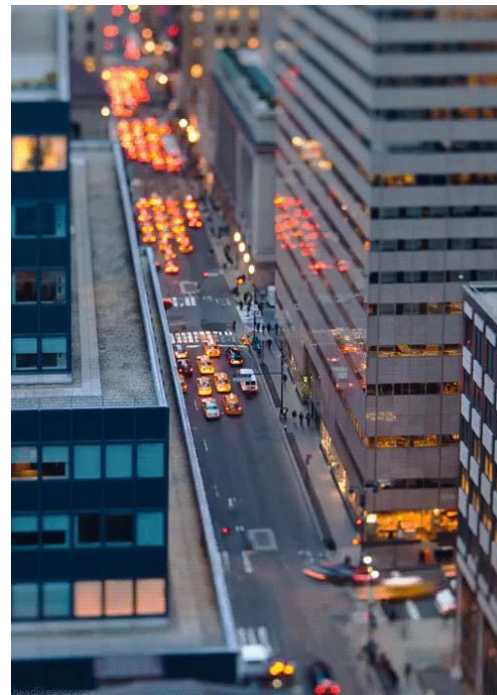
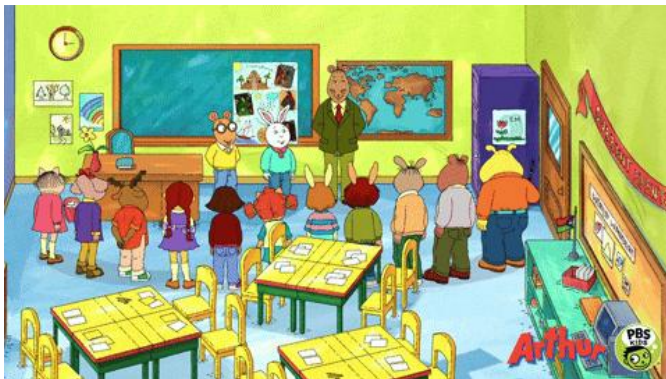

Outline of Lecture 2

- Physical World as Input
- Signal as Input
- Knowledge as Input

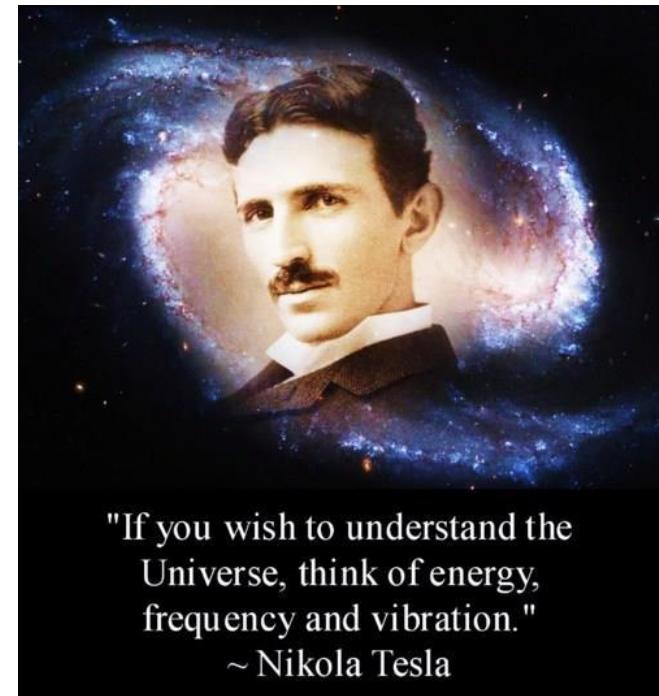
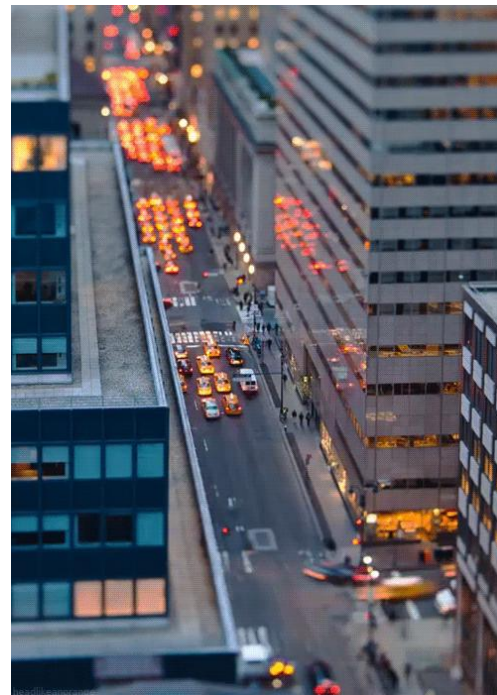
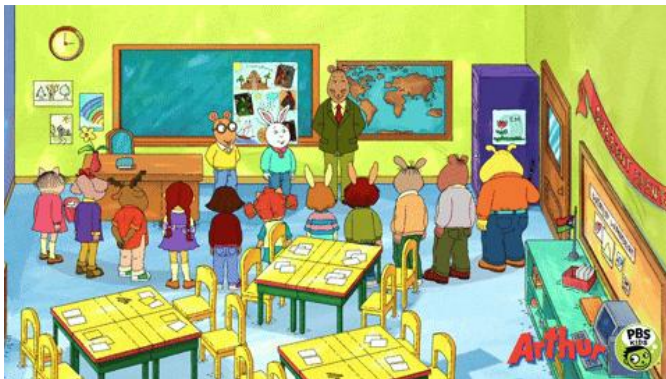

What is the physical world?

Physical World

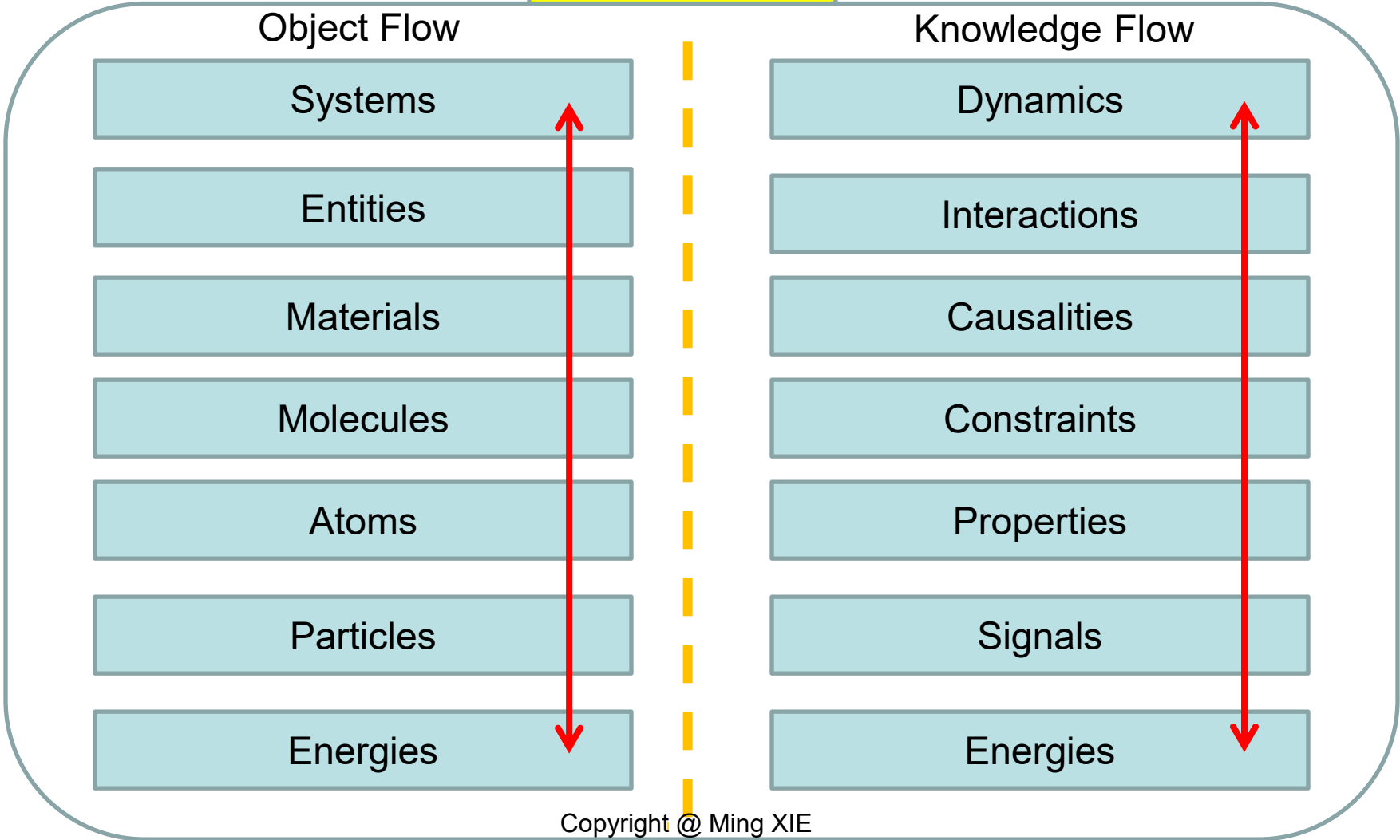

Copyright @ Ming XIE

The physical world is visible ...



Plants



Rivers

The physical world is visible ... (continued)

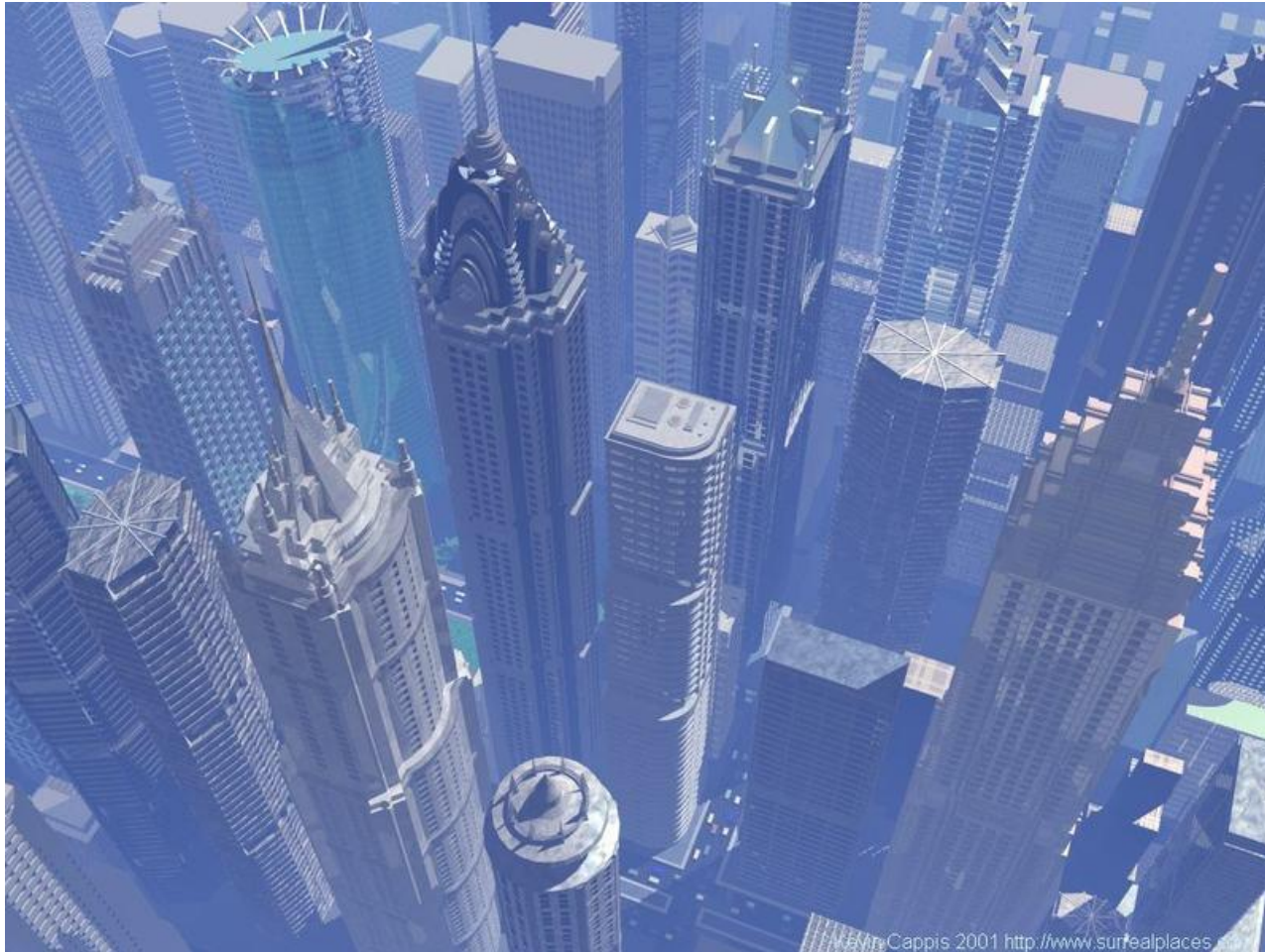

Buildings

(Learning, Teaching) <o> (Research, Innovation) <o> (Leadership, Service)

The physical world is visible ... (continued)



Bridges

The physical world is visible ... (continued)



Roads

The physical world is visible ... (continued)



Cars and Streets

The physical world is visible ... (continued)



Ships and Boats

The physical world is visible ... (continued)



Airplanes

The physical world is visible ... (continued)



Tanks

The Physical World Has Dimension

- System Levels
- Entity Levels
- Material Levels

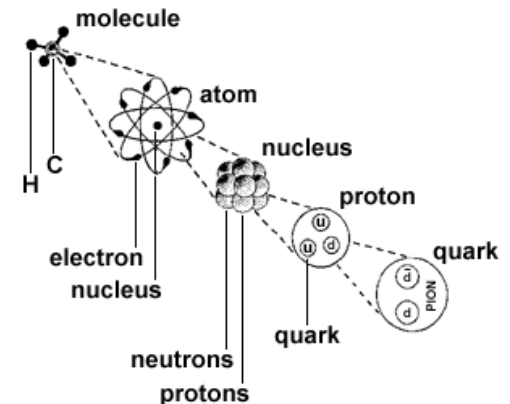
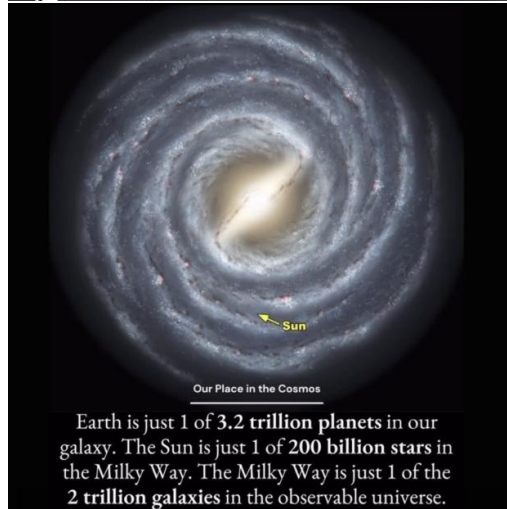

All the entities in the physical world has four states

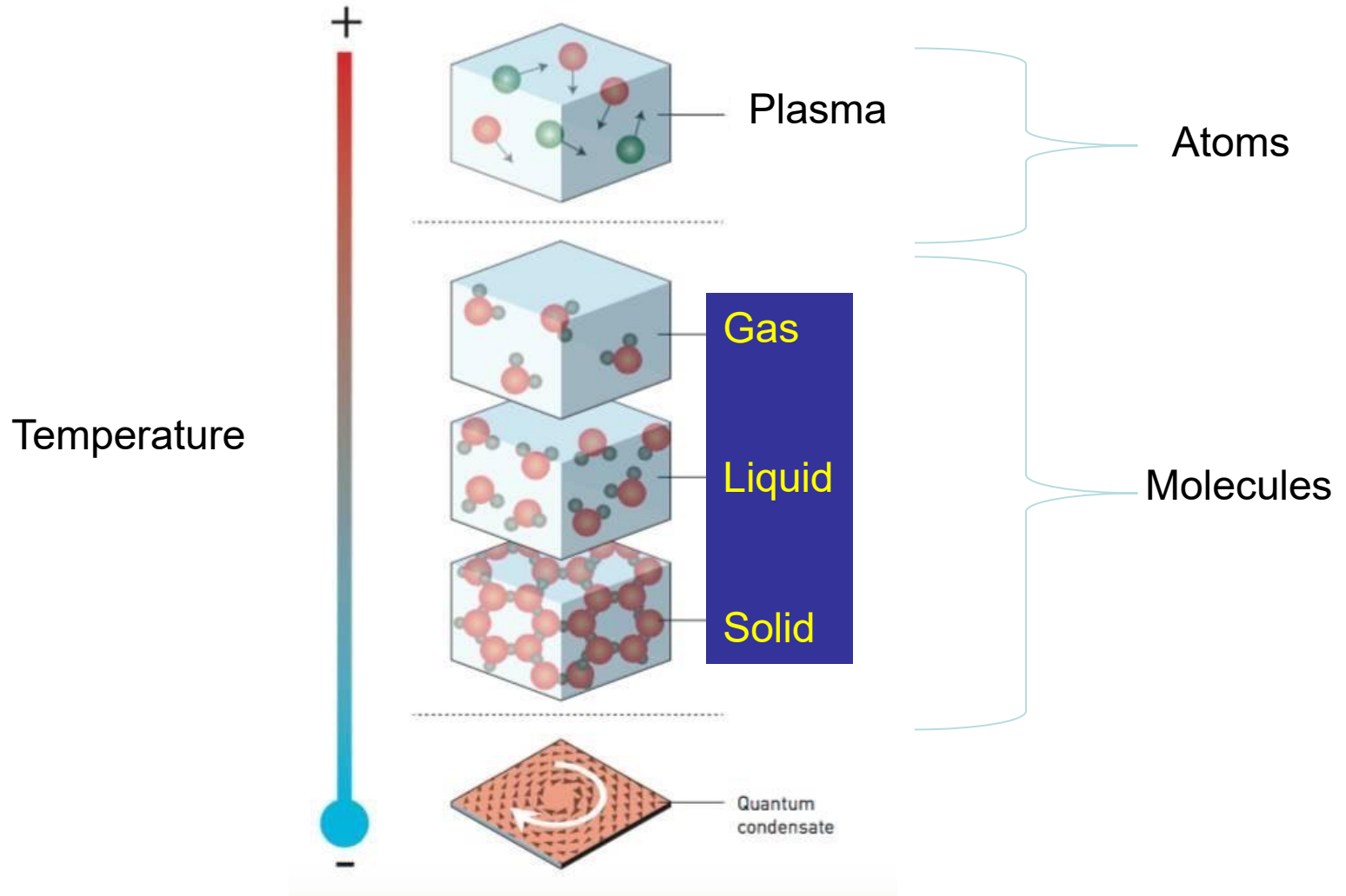

All the entities in the physical world are organized into a hierarchy of physical systems ...

- Physical entities in the physical world could act and interact together.
- All the physical entities which act and interact together for the purpose of achieving common goals are forming specific groups which are called as **Physical Systems**.
- The physical systems could be categorized into: a) static systems, and b) dynamic systems.
- The dynamic systems could be operated in the mode of: a) systems without control, or b) systems with control.



- The best systems are static systems
- The best dynamic systems are LTI systems.

Example of Static Systems

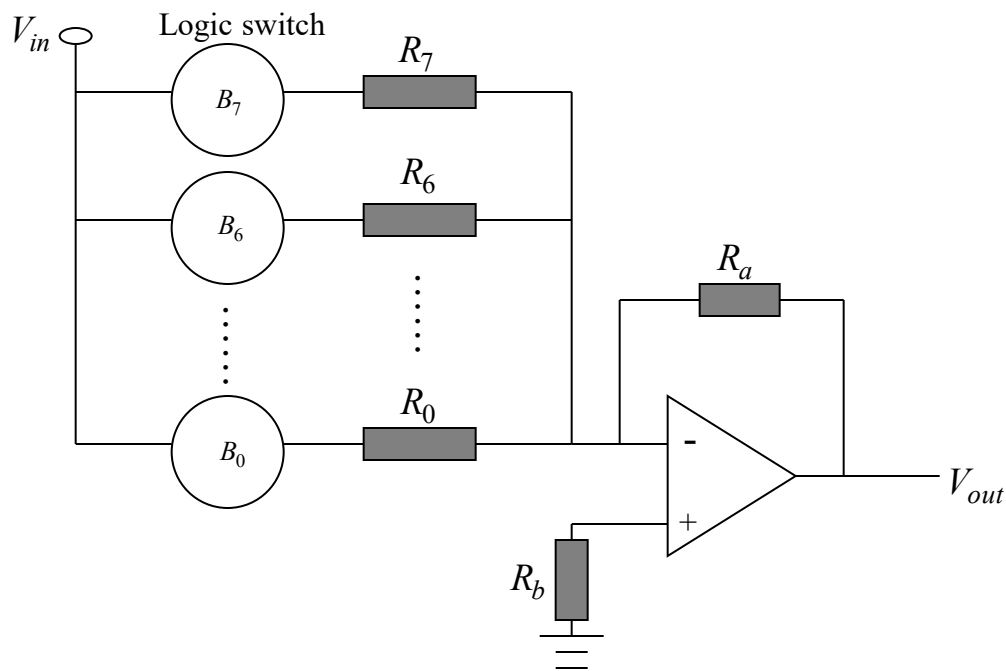

The best systems in the universe are static systems!

Example of Dynamic Systems with Control

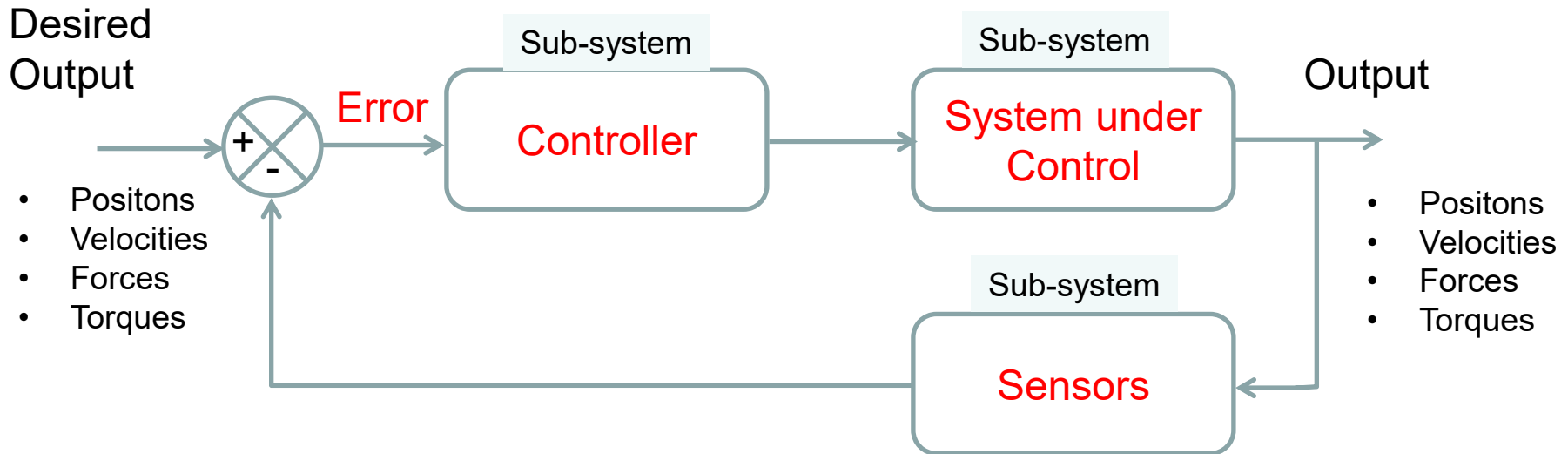

Our mission on Earth is to transform dynamic systems to be closer to static systems!

Outline of Lecture 2

- Physical World as Input
- Signal as Input
- Knowledge as Input

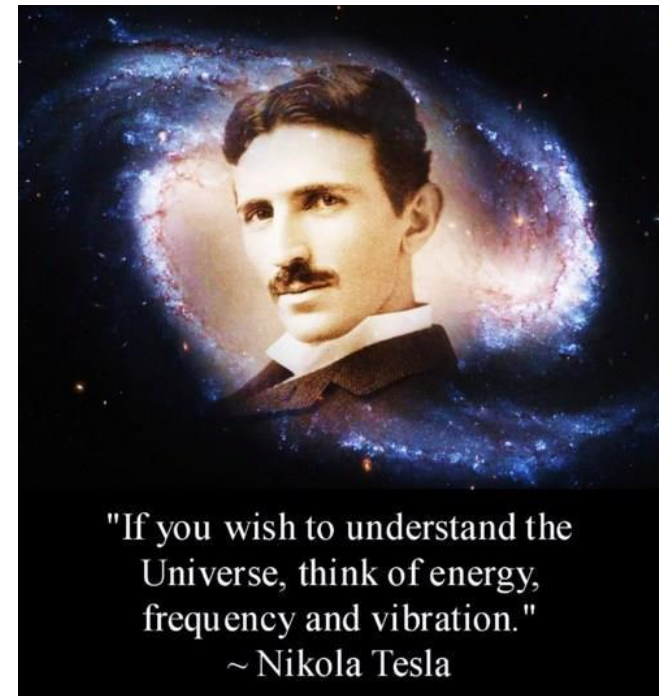
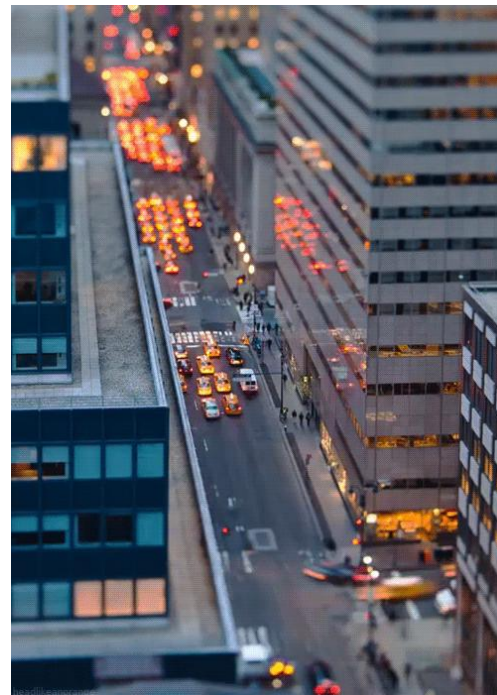
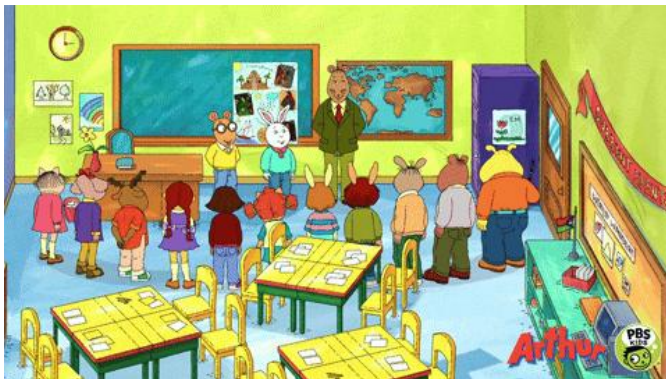

All existences in the universe are manifestations of energies

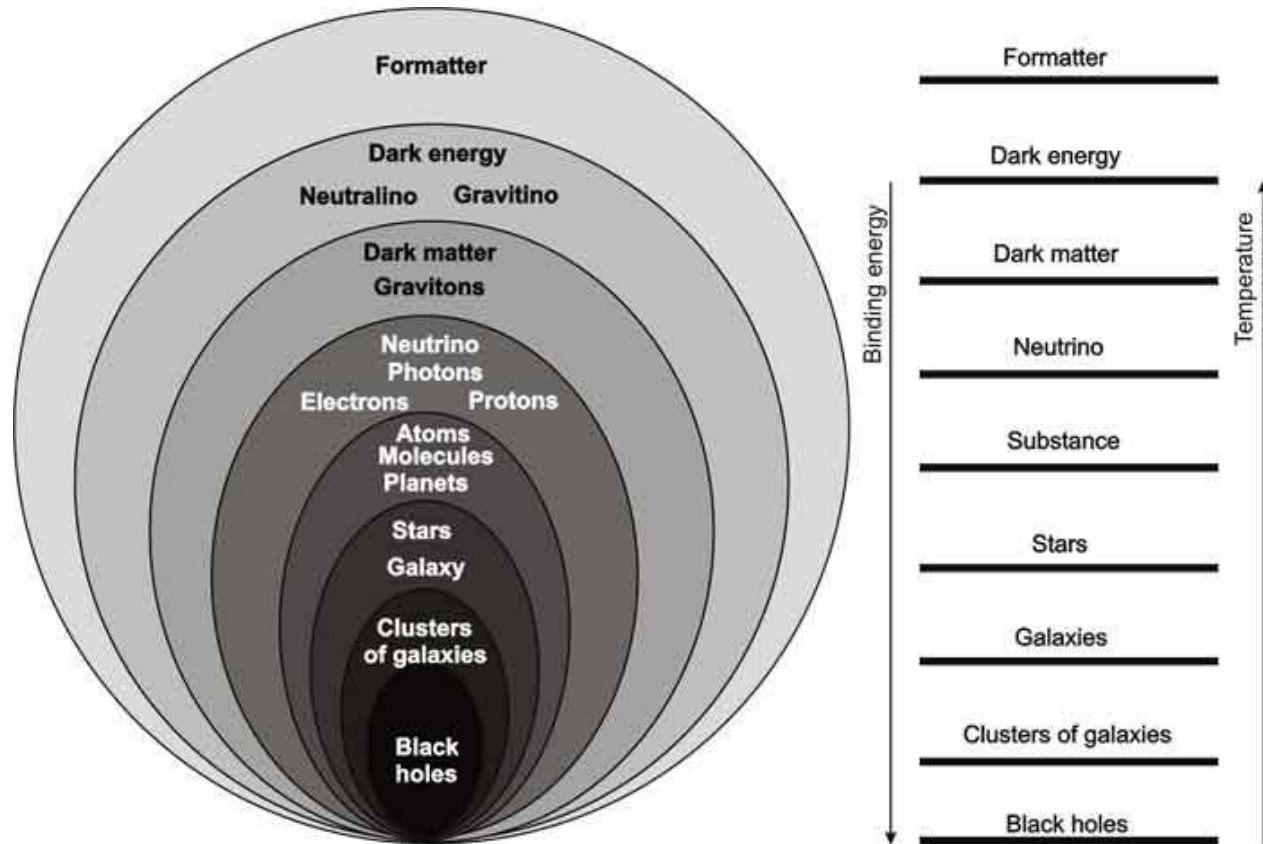

Energy could be manifested in the form of mass and speed (case 1)

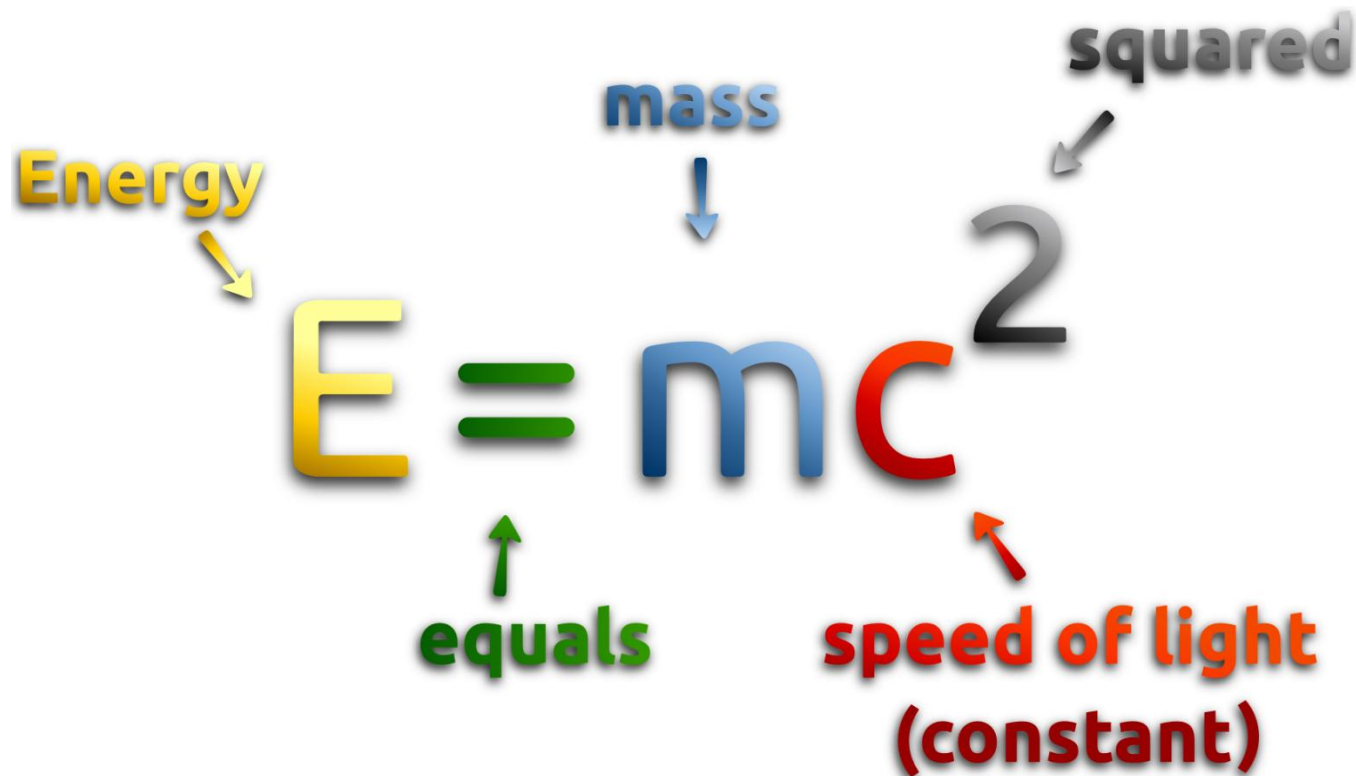

The diagram illustrates the equation $E = mc^2$ with the following labels and arrows:

- Energy** (yellow text) with a yellow arrow pointing to the letter **E**.
- mass** (blue text) with a blue arrow pointing to the letter **m**.
- squared** (grey text) with a grey arrow pointing to the superscript **2**.
- equals** (green text) with a green arrow pointing to the equals sign **=**.
- speed of light (constant)** (red text) with a red arrow pointing to the letter **c**.

Energy could manifested in the form of mass and speed (case 2)

$$E = \frac{1}{2} m \cdot v^2$$



Energy could be manifested in the form of mass and the relative height

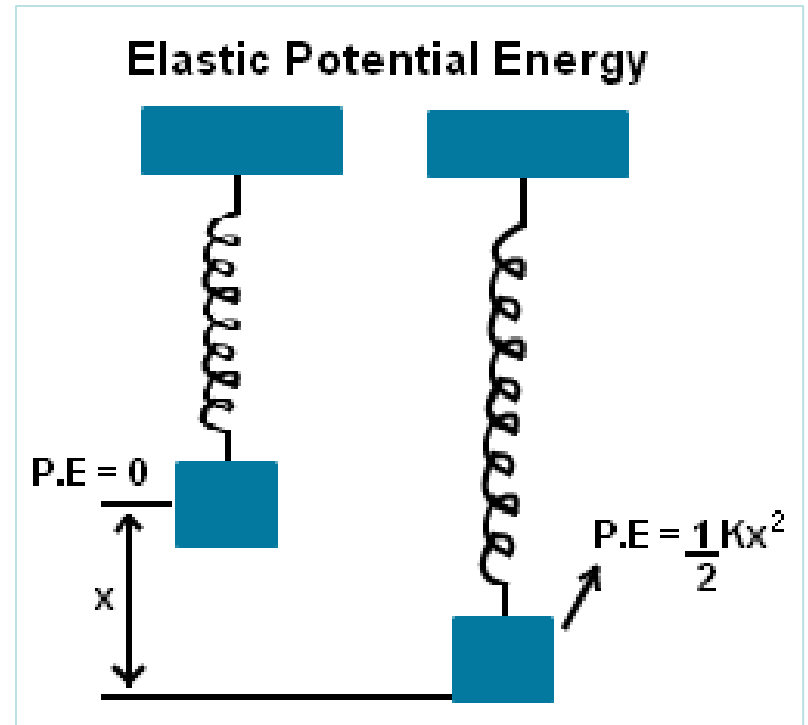
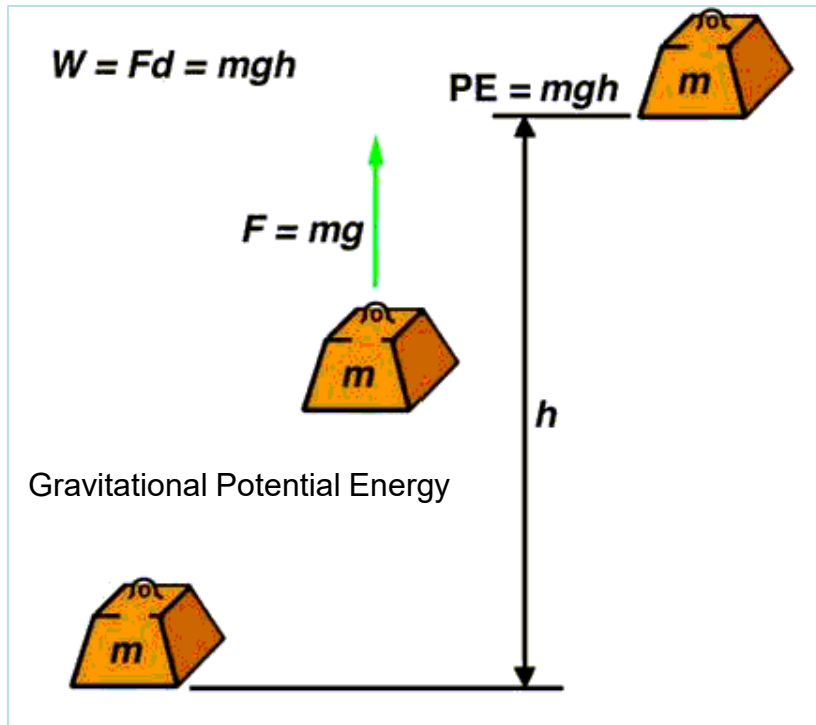

Energy could also be manifested in the form of force which makes a mass to undertake a displacement

$$W = Fd \cos \theta.$$

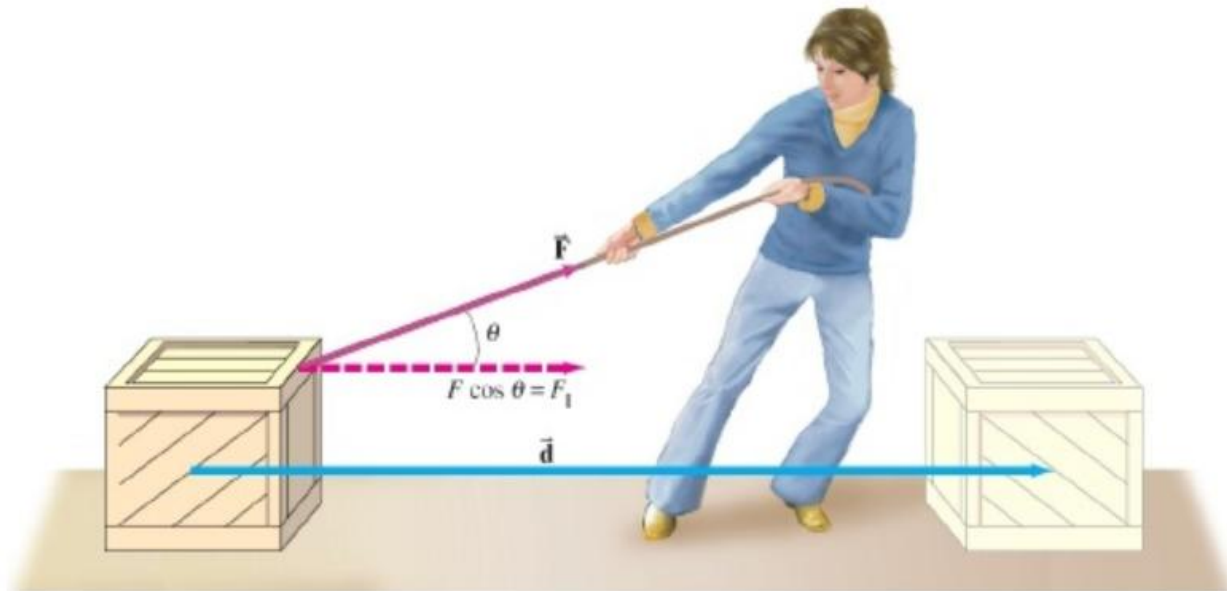

Variations of energy create signals

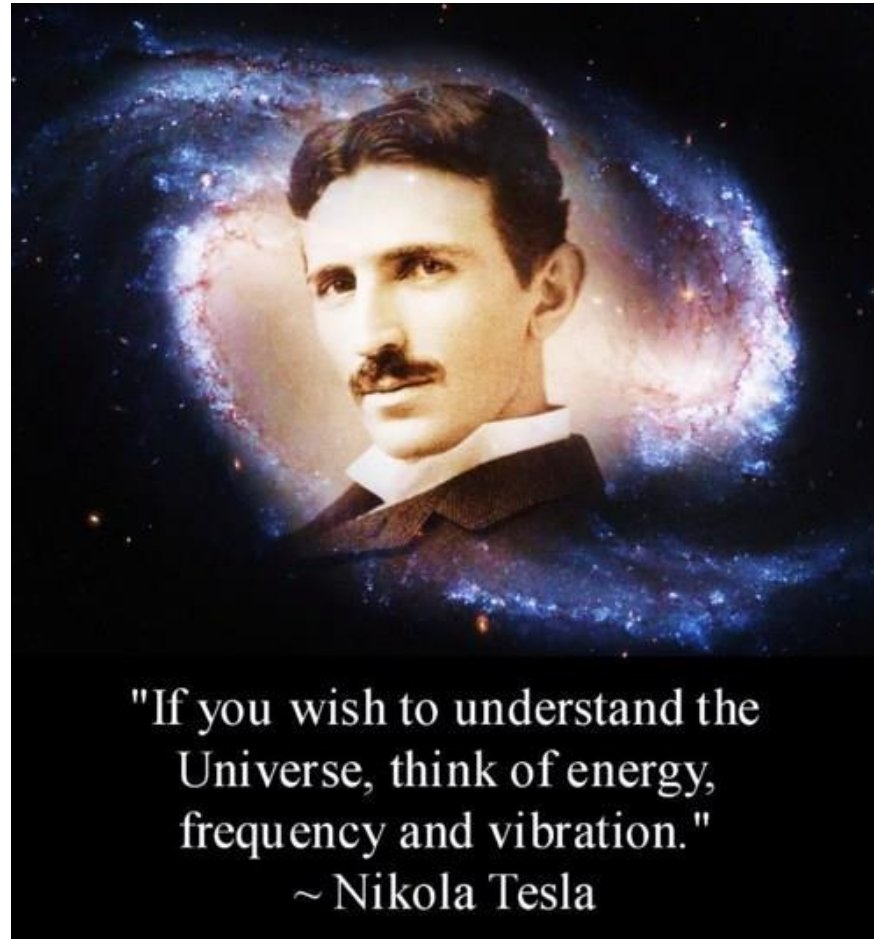

Signal is vibration ...

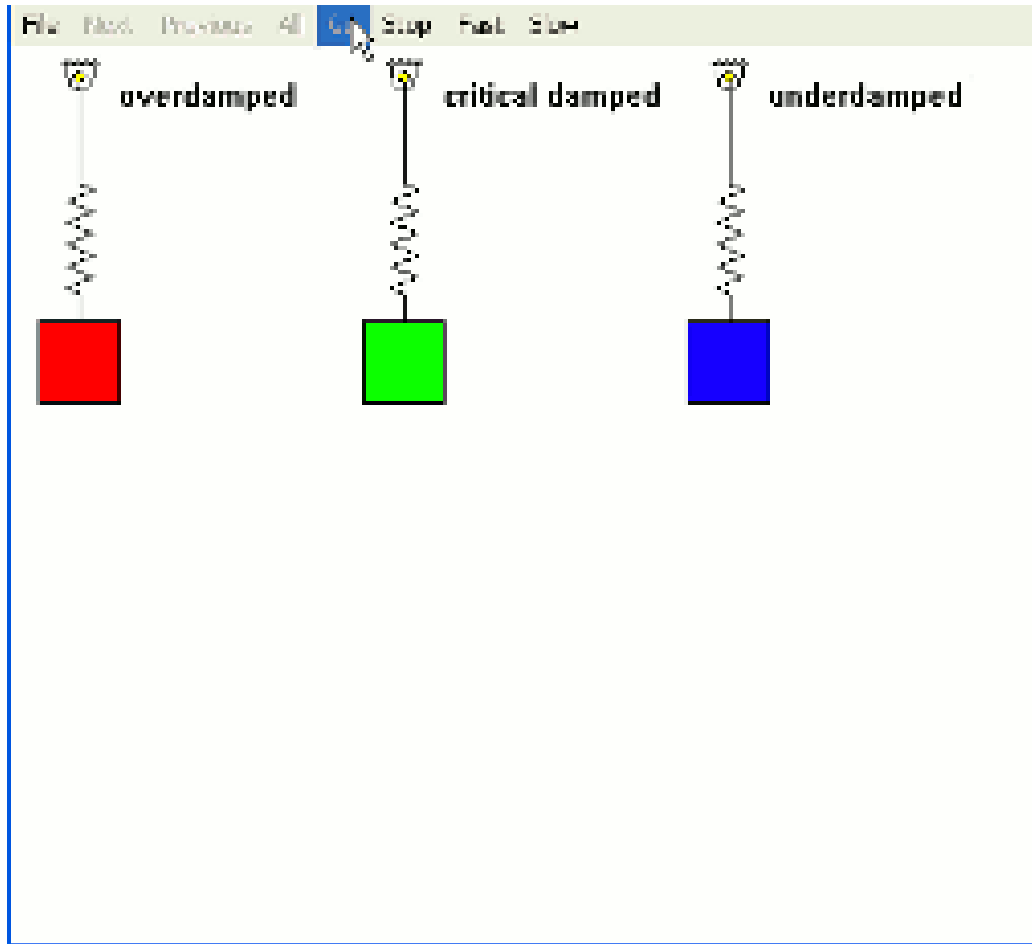

Signal is oscillation ...

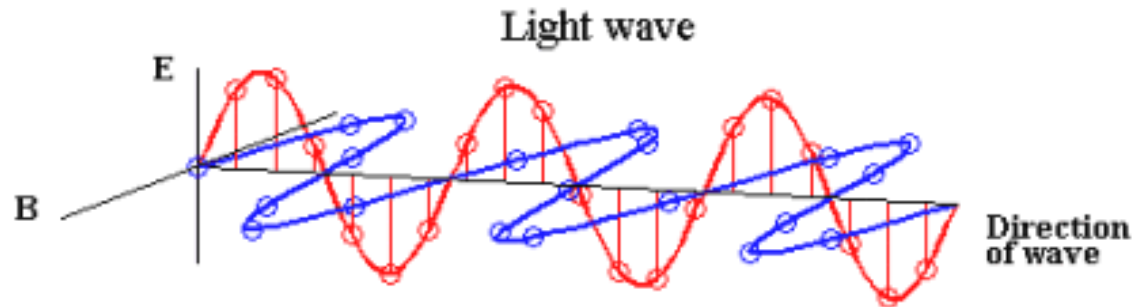
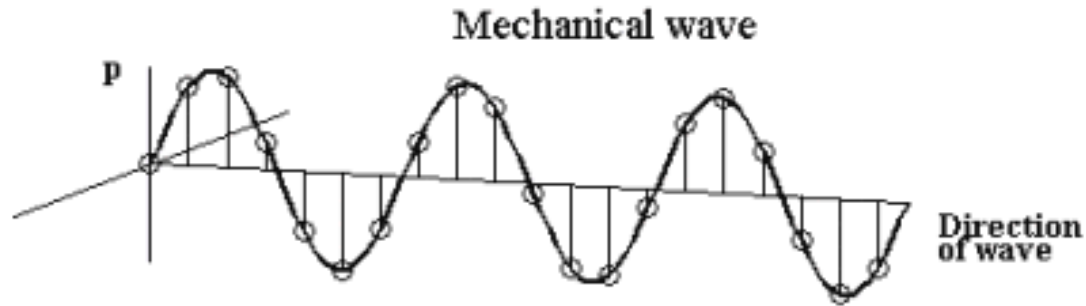

Signal is sine wave ...

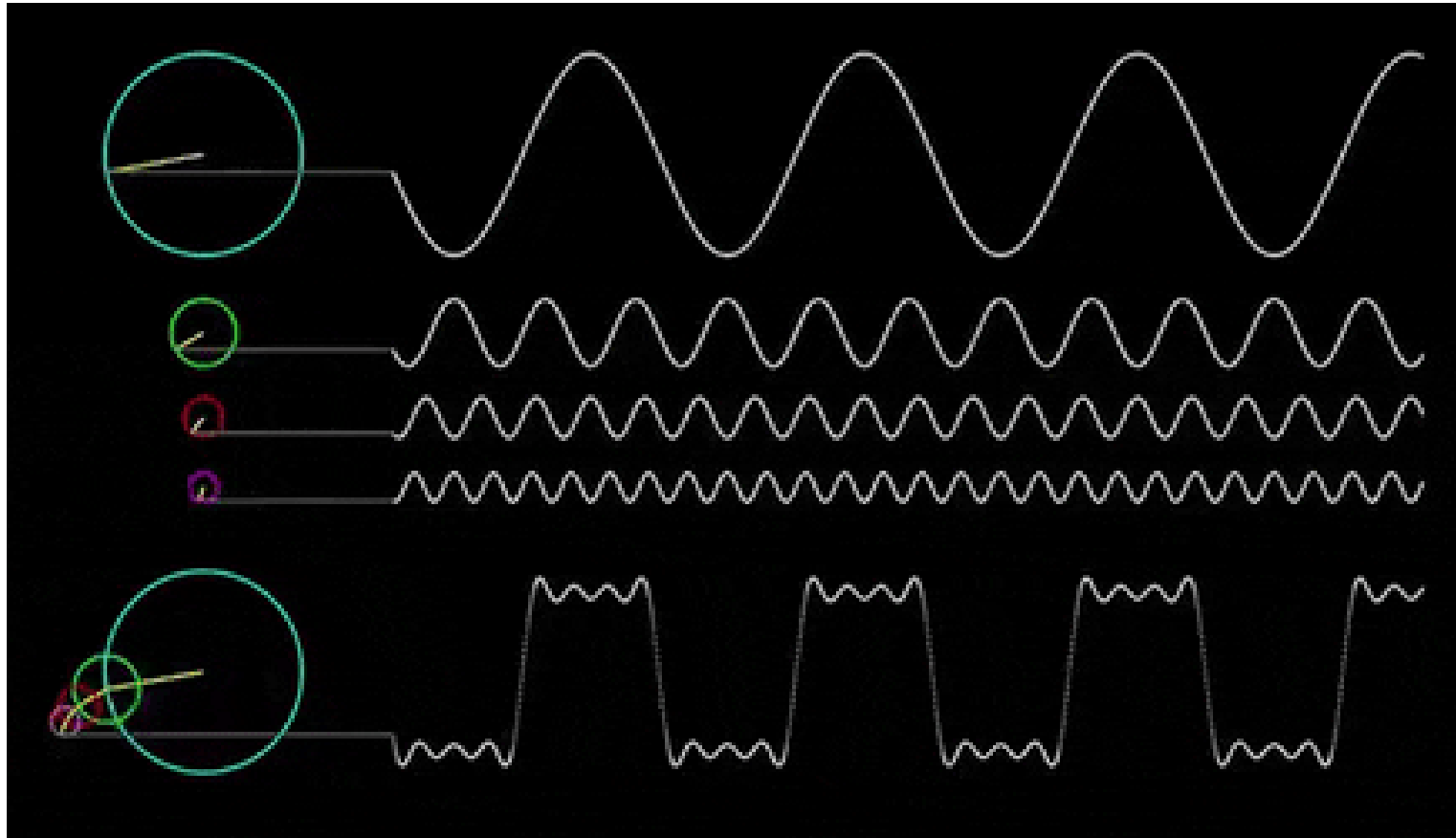

Outline of Lecture 2

- Physical World as Input
- Signal as Input
- Knowledge as Input

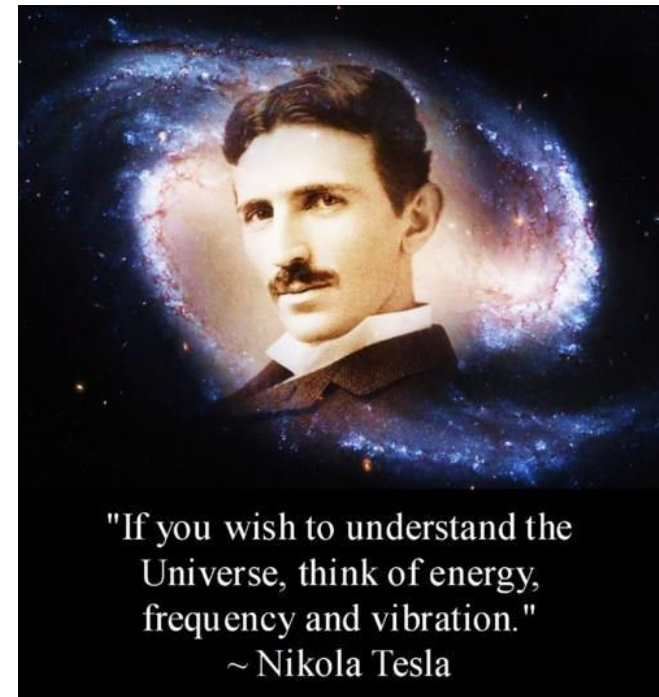
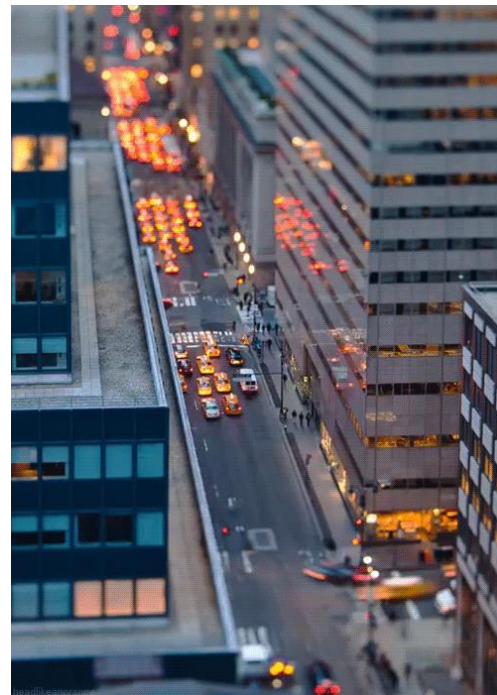
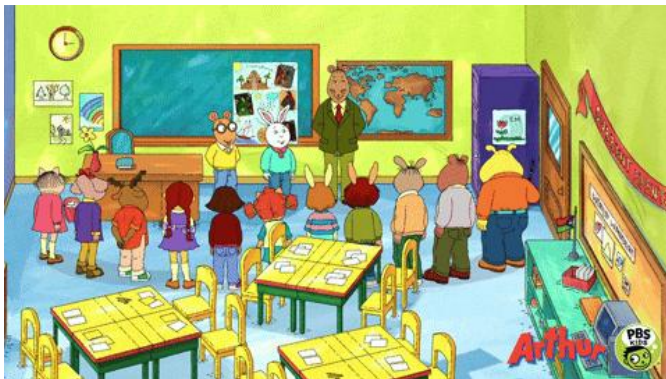

What is knowledge?

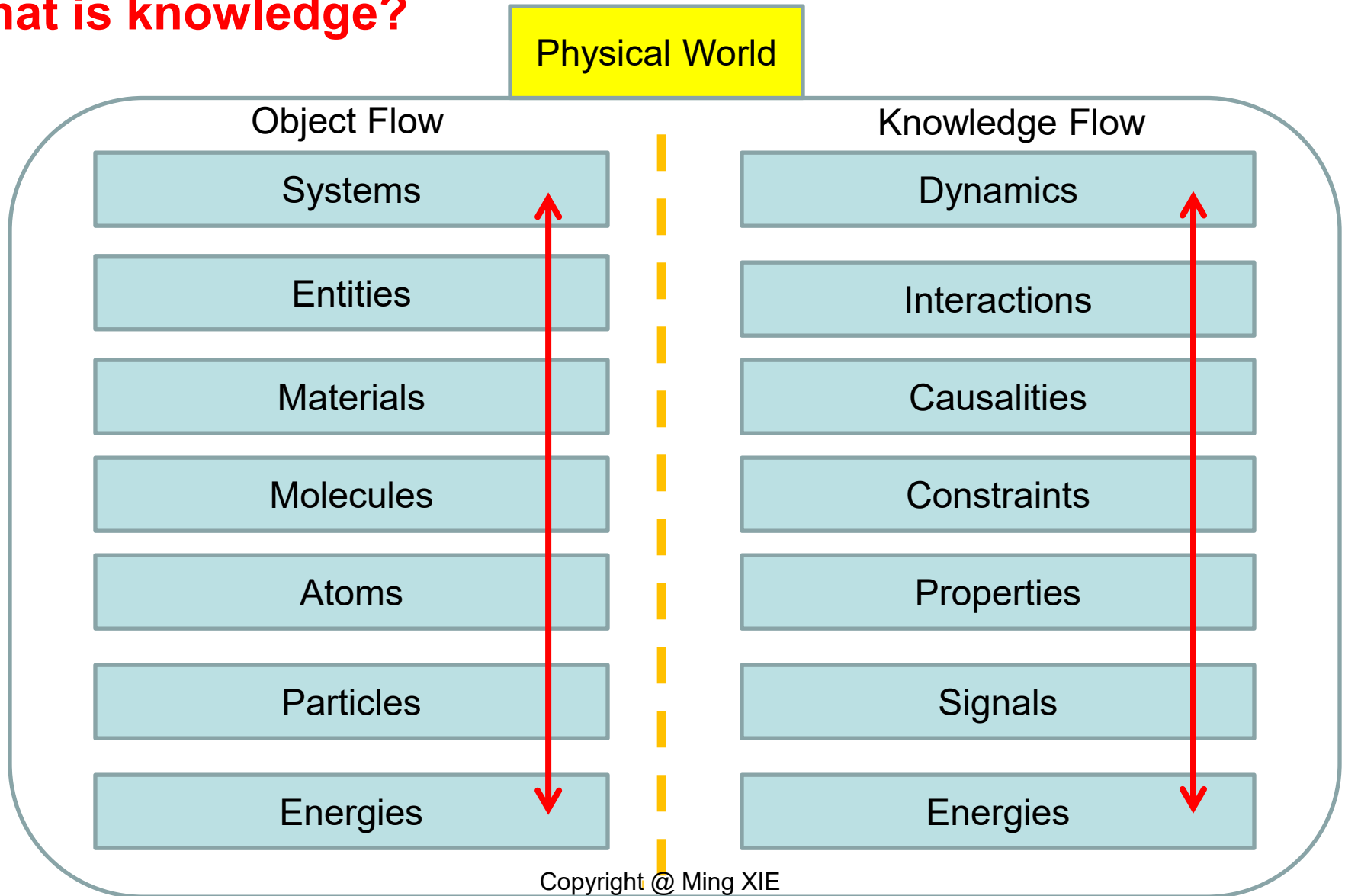

Energy is at the origin of knowledge creation ...

- Energy creates dynamics

- Dynamics creates signals

What is physical quantity?



- Signals create observable quantities

- **Quantities** enable perception by observers

What is knowledge?



- Perception by observers results in understood knowledge

- Knowledge result in the creation of human languages, etc.

Definition of Physical Quantities

- Physical quantities refer to the physical properties which are possessed by physical entities or physical systems.



Categories of Physical Quantities

Visible

- Length
- Height
- Volume
- Dimension
- Shape
- Colour

Invisible

- Energy
- Mass
- Weight
- Force
- Friction

Example of Visible Physical Quantities ...

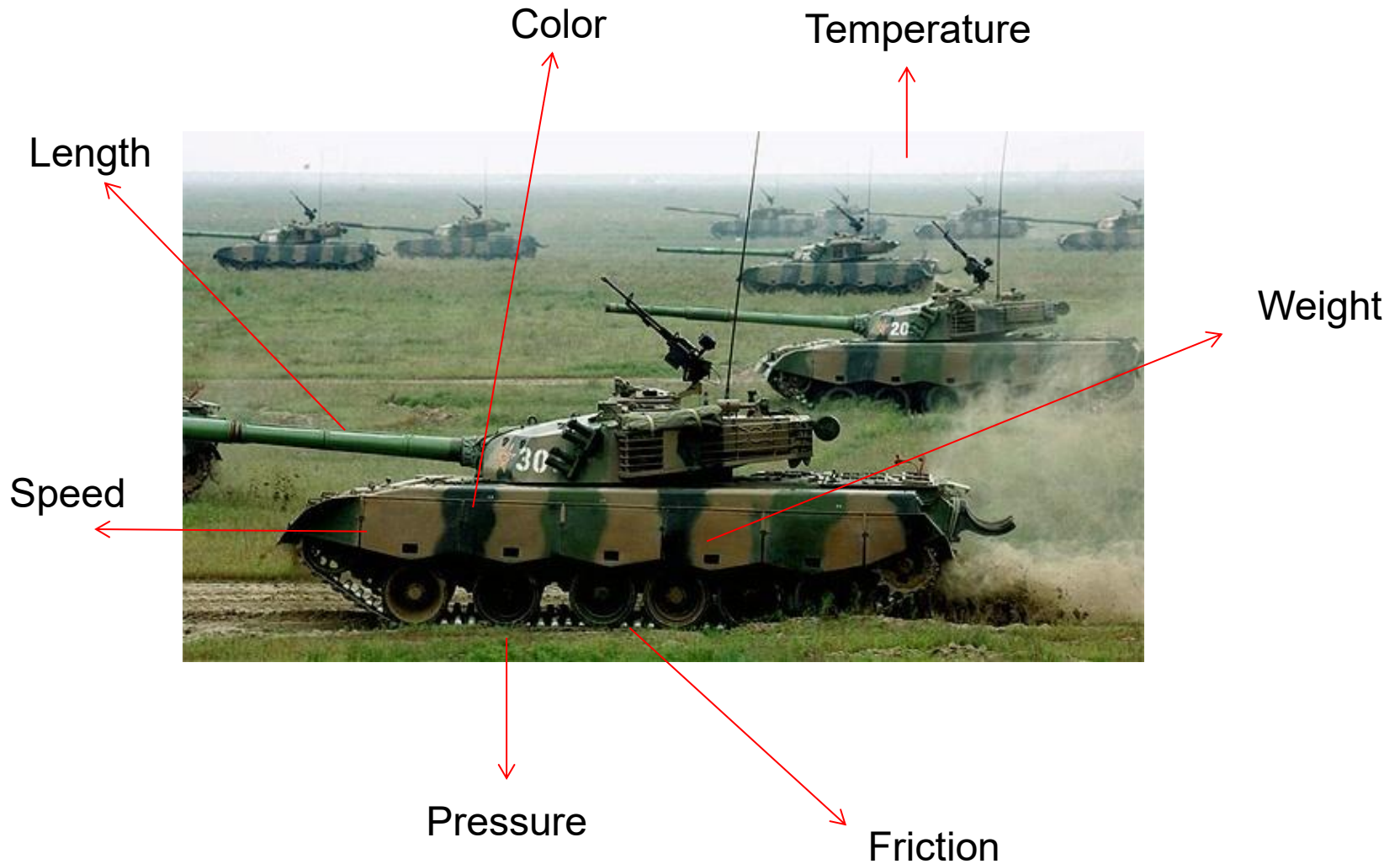

Human beings are intelligent creatures who are interested in knowing ...

- How to understand the world?
 - Science (Discovery)

- How to change the world?
 - Engineering (Invention)



How to Understand a Physical World with 1 Entity?

- There are physical properties about the entity.
- There is no interaction.

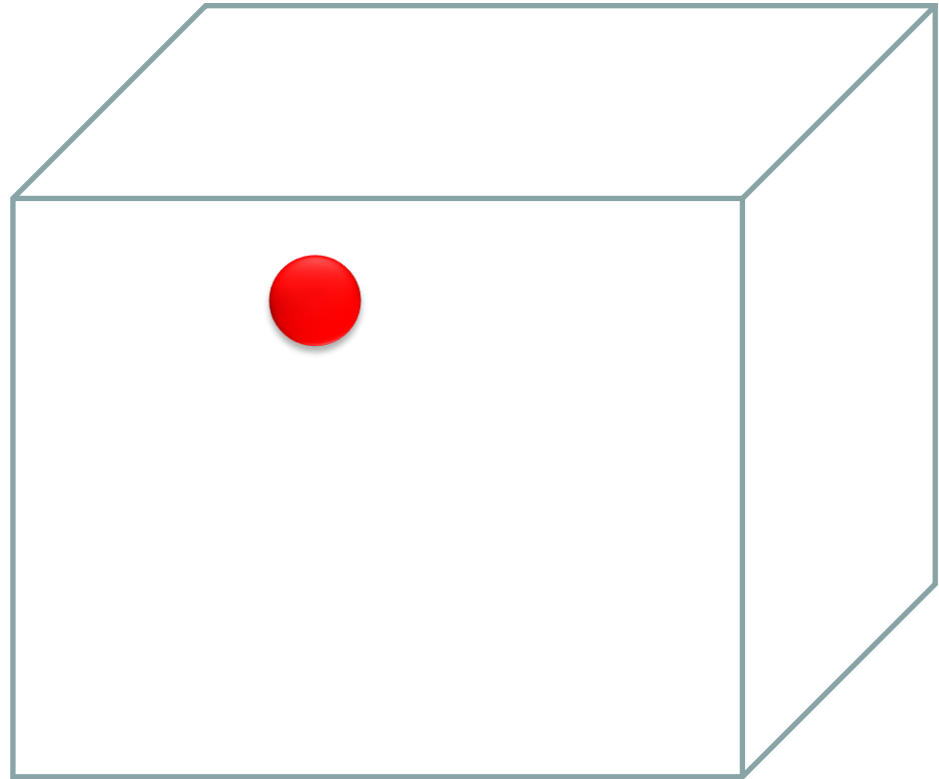

How to Understand a Physical World with 2 Entities?

- There are physical properties about these two entities.
- There are mutual interactions.
- Interactions create relationships.
- Relationships include:
 - Membership
 - Family
 - Category

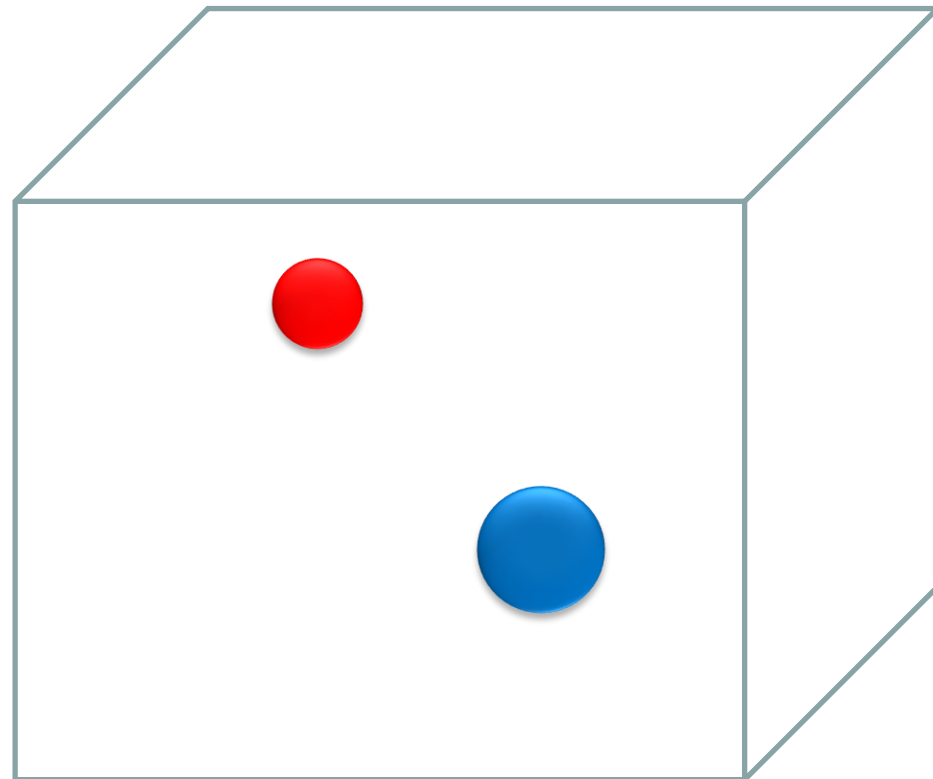

How to Understand a Physical World with N Entities?

- There are physical properties about these entities.
- There are multiple interactions.
- Interactions create relationships.
- Relationships include:
 - Membership
 - Family
 - Category, etc.

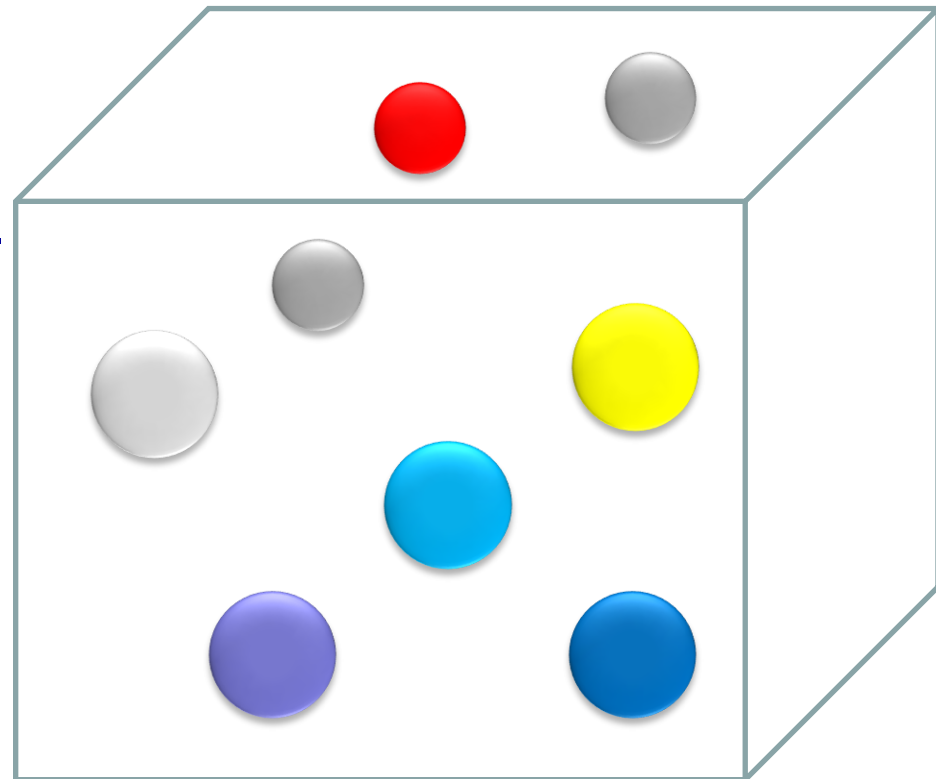

Definition of Properties

- The physical quantities, which are related to the self-existence of a physical entity, are called properties.



Example of Properties

A human being

- Mass
- Height
- Gender
- Volume
- etc

A car

- Mass
- Length
- Width
- Colour
- etc

Scenario of Self-Existence of 1 Entity

- The existence of an entity depends on its properties such as
 - Physical/chemical/biological/social/properties, etc.
- The existence of an entity is subject to space constraint such as
 - Position
 - Dimension
 - Direction
- The existence of an entity is subject to time constraint such as
 - Life span
 - Self-behaviors as a function of time



Scenario of Co-Existence of N Entities

- The co-existence involves interactions among N entities such as
 - Action
 - Reaction
- The co-existence is subject to space constraint such as
 - Configuration
 - Topology
- The co-existence is subject to time constraint such as
 - Self- and interactive behavior as a function of time
 - Event as a function of time
 - Episode as a function of time



Definition of Constraints

- The physical quantities, which are related to the co-existence of multiple physical entities, are called constraints.

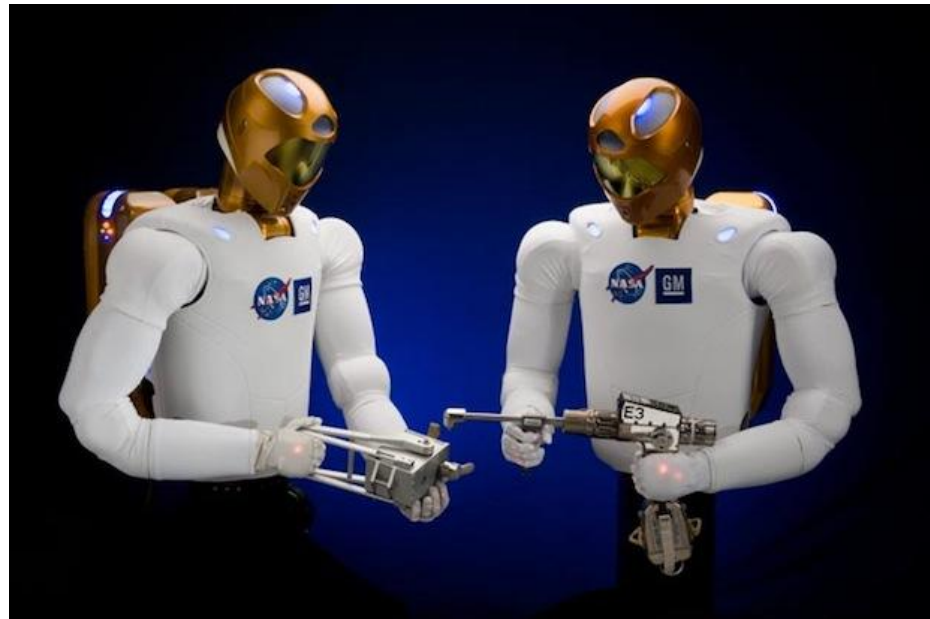

Example of Constraints

A human being

- Weight
- Position
- Age
- Degrees
- etc

A car

- Weight
- Velocity
- Owner
- Price
- etc

Example of Spatial Constraints (1)

- Position/Velocity/Acceleration/Weight (Gravity)

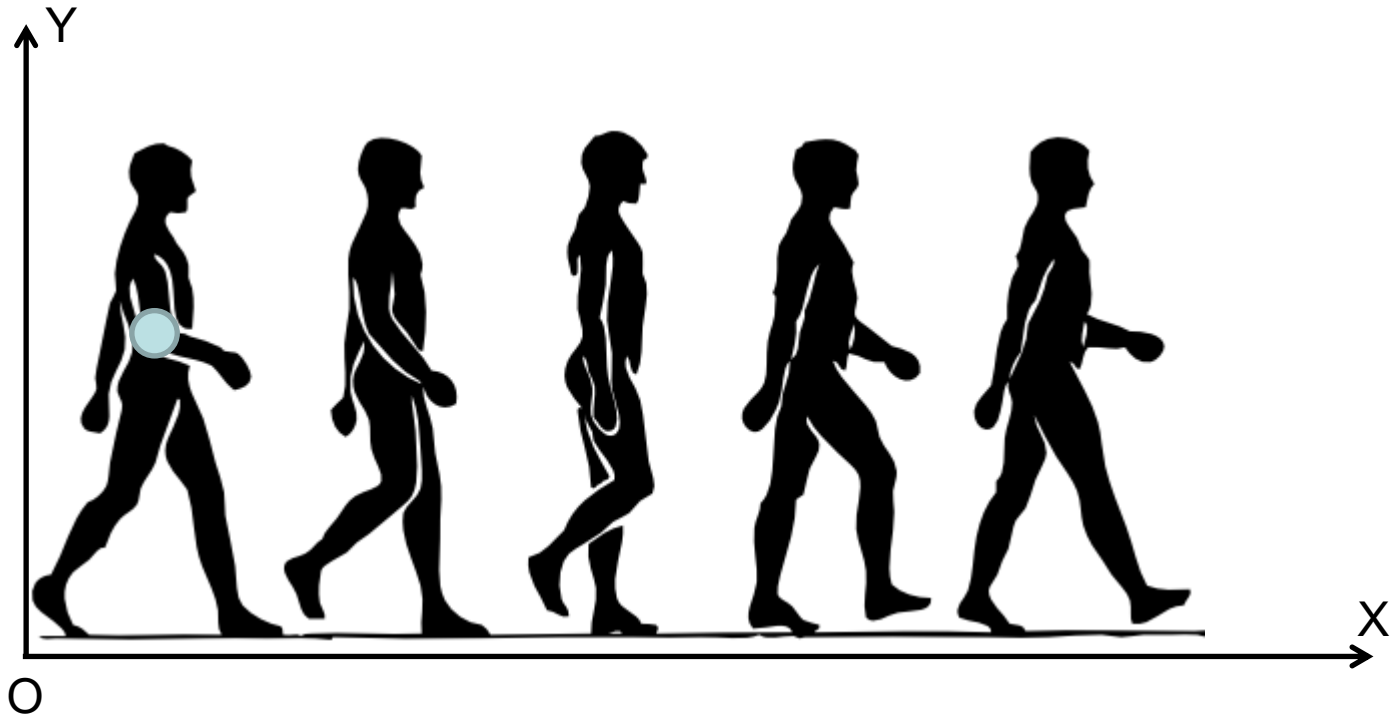

Example of Spatial Constraints (2)



Definition of Behaviours

- Evolutions of properties (statics) and constraints (dynamics) as functions of time are called behaviours.

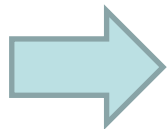

Now, we are ready to define knowledge

Definition of Knowledge

- The properties (statics), constraints (dynamics) and their evolutions (i.e. behaviours) among N interacting entities consist of knowledge in the physical world.

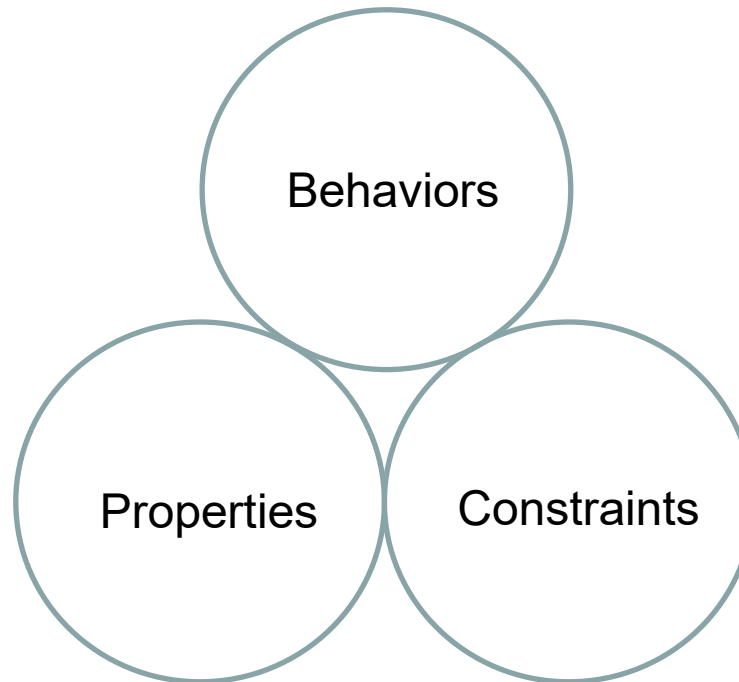

Knowledge = Statics + Dynamics

Properties and Constraints Dictate Dynamics and History Among N Entities ...

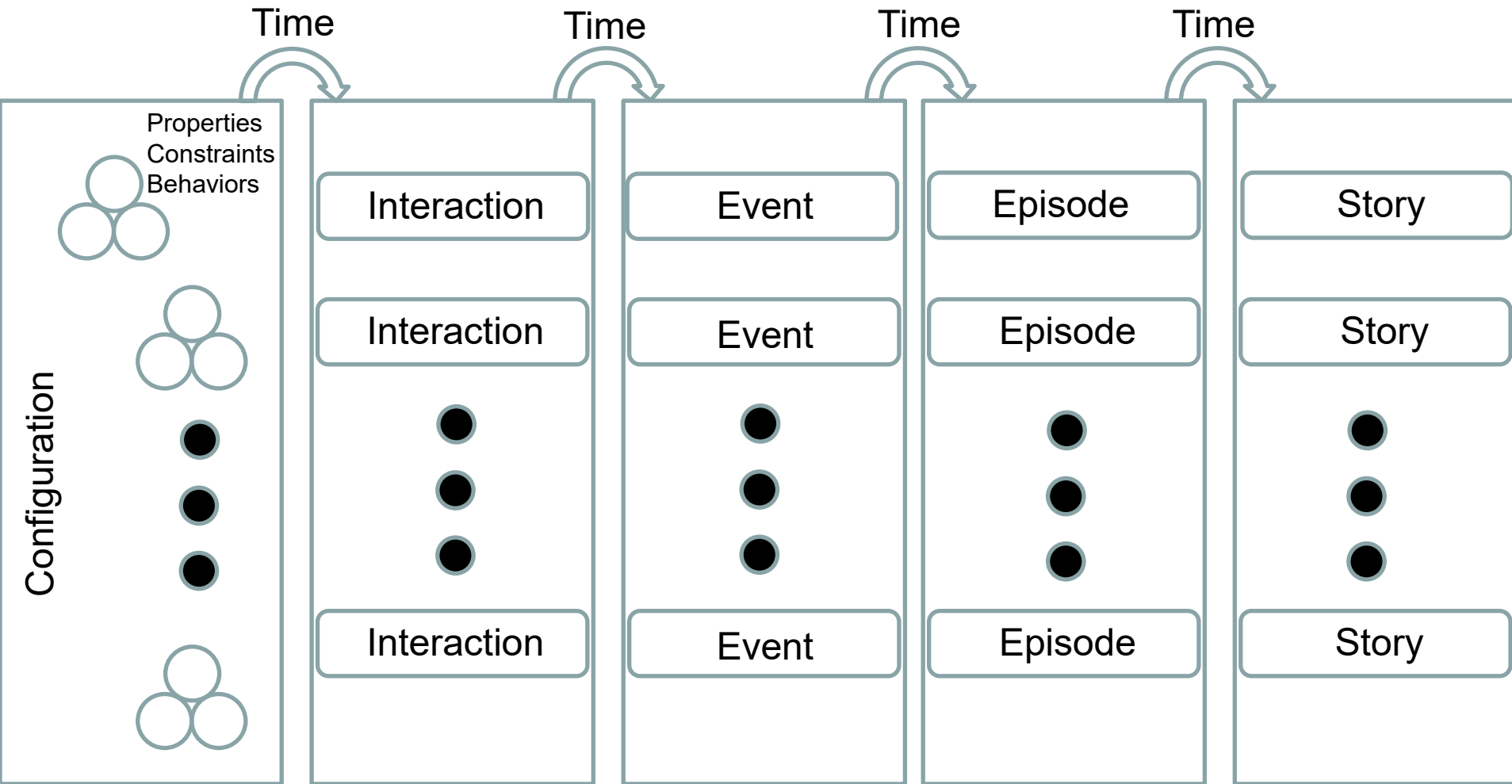

Example of Properties and Dynamics



RoboCup versus Football Cup ...



1990s

April 2024



There are two types of knowledge from the physical world

Propositional Knowledge

- Property-related
 - Theory
 - Principle
 - Method
 - Concept

Procedural Knowledge

- Constraint-related
 - A series of decisions in a process or procedure
 - A series of instructions in a process or procedure
 - A series of skills in a process or procedure

Example of Propositional Knowledge

- Newton said: Acceleration is proportional to the applied net force, and inversely proportional to the mass.
- What is this type of knowledge?
- Answer:
 - Propositional knowledge, which is about property, theory, principle, method and concept.

Example of Procedural Knowledge

- A monitor says: When you see a traffic light to change to red, you must brake and stop. When you see a slowly moving vehicle, you should follow it if you cannot change the lane, or by-pass it if you can change the lane; When you are at a junction, you must give priority to cars coming from your right side (or your left side).
- What is this type of knowledge?
- Answer:
 - Procedural knowledge, which is about decision, instruction, or skill, behind process.

How to represent propositional knowledge?

- Answer:

- Books
- Theses
- Reports
- Papers
- Articles
- Other texts or media

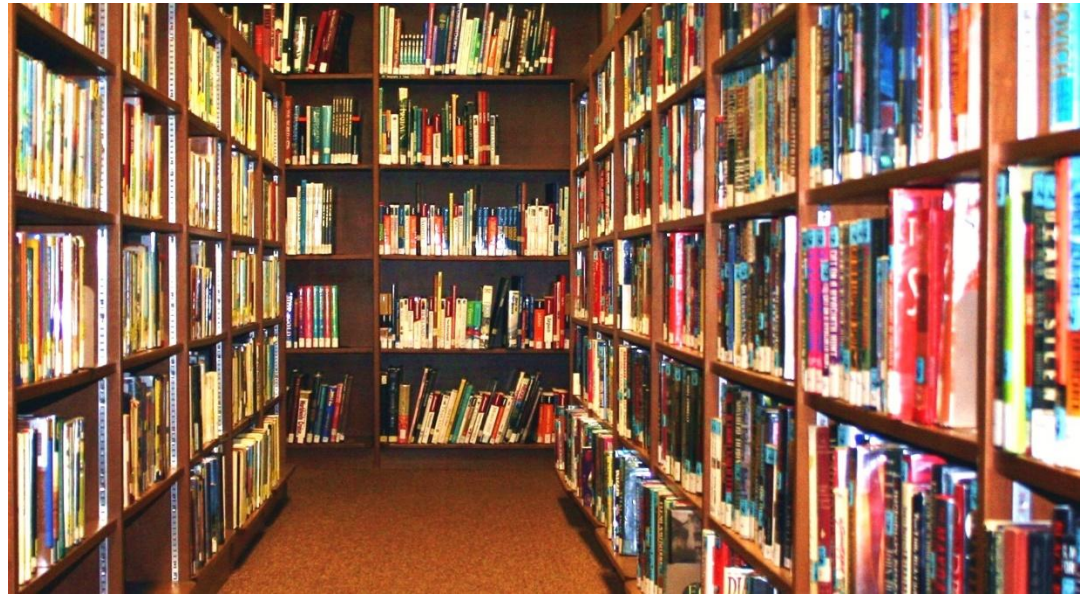

Example

- What is a straight line?

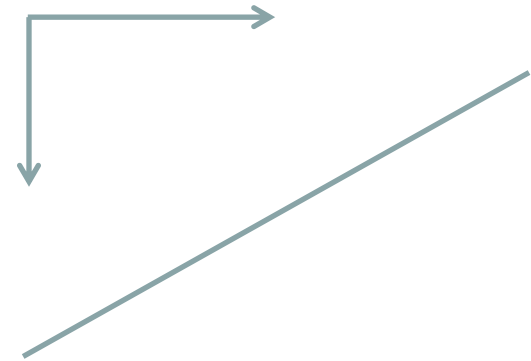

- Answer:
 - It is a line along which the change rate of displacement is always the same.

How to represent procedural knowledge?

- Answer:

- Networks or trees of decisions
- Networks or trees of rules
- Networks or trees of logics

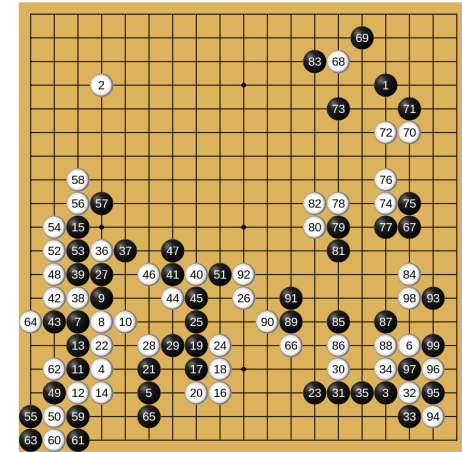

AI 1.0

Example

- How to successfully study in a University?
- Answer:
 - To listen
 - To read
 - To practice
 - To write
 - To present



Also, there are two types of knowledge from the viewpoint of learners

Explicit Knowledge

- Directly-perceived knowledge from the sensory systems
 - Colors
 - Shapes
 - Textures, etc

Implicit Knowledge

- Indirectly computable knowledge by the minds
 - Equations of Kinematics
 - Equations of Dynamics
 - Equations of Paths, etc

Therefore, there are four types of knowledge in both the physical world and conceptual worlds

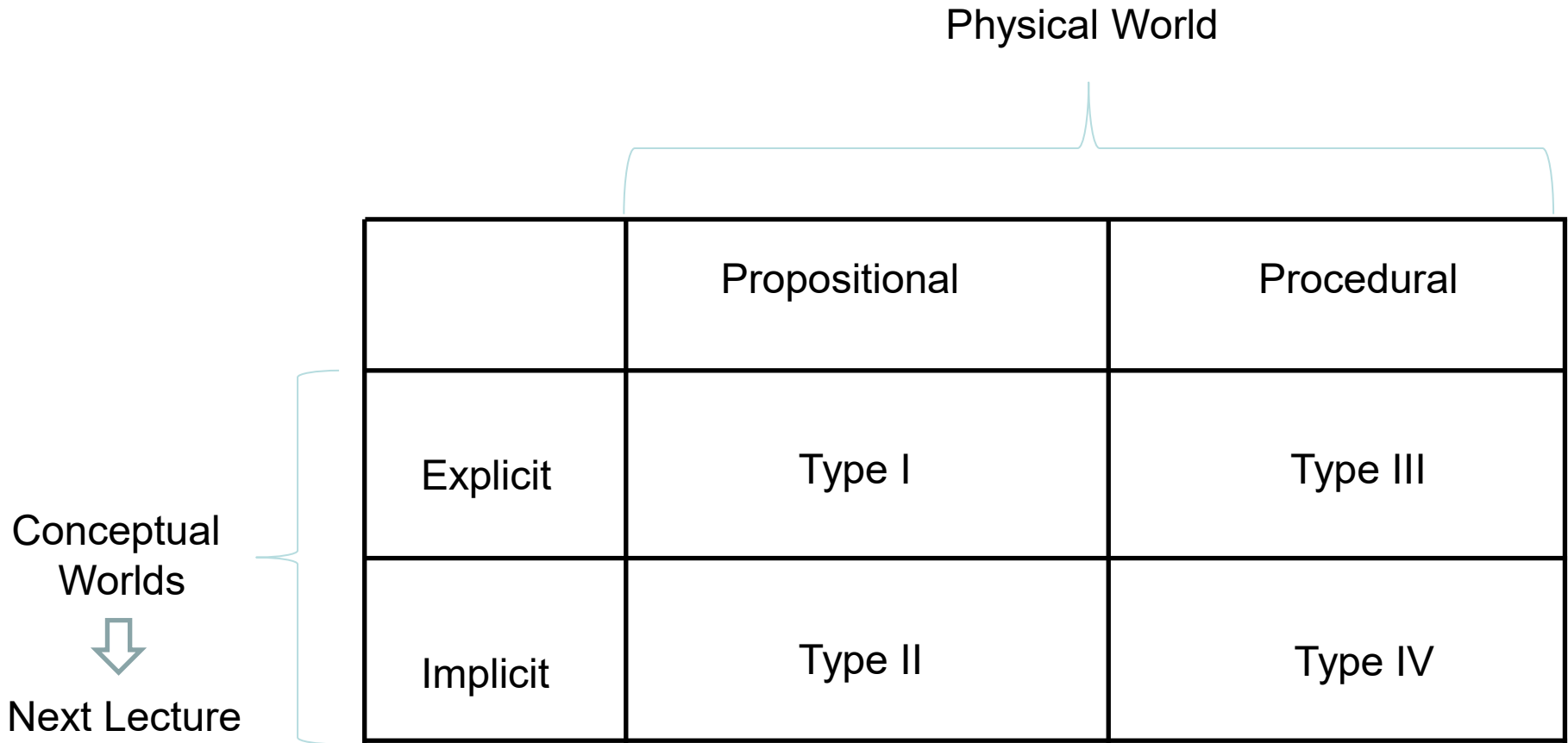

Exercise

- What are a) the explicit propositional knowledge , and b) implicit propositional knowledge, that you can describe when you see the picture below?



Answer about explicit propositional knowledge:

- It is a tank.
- The tank is moving on a road.
- The road is near a forest.
- The tank has six wheels at each side.

Answer about implicit propositional knowledge:

Kinematics

- The speed of the tank is the sum of its initial speed and the increment of speed due to acceleration.

Dynamics

- The acceleration of the tank is proportional to the net force acting on it, and is inversely proportional to the mass of the tank.

How to discover knowledge from the physical world?

How to represent knowledge from the physical world?

Summary of Lecture 2

- Physical World as Input
- Signal as Input
- Knowledge as Input

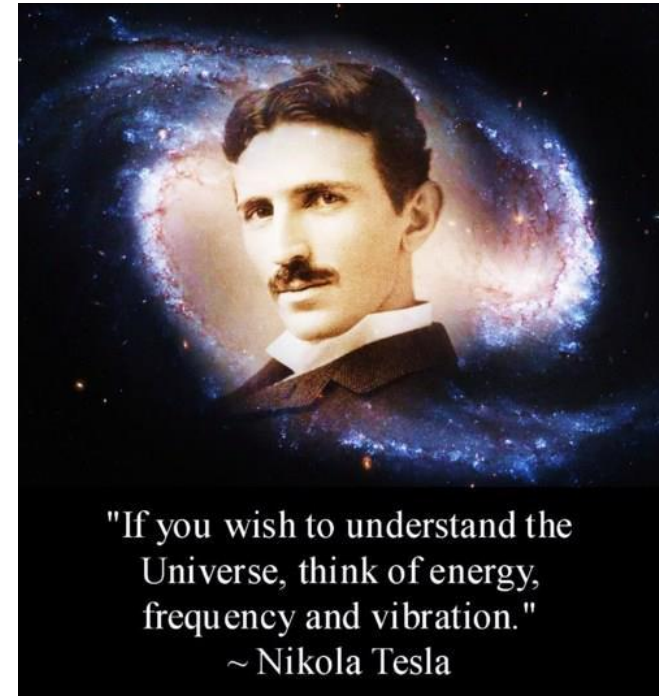
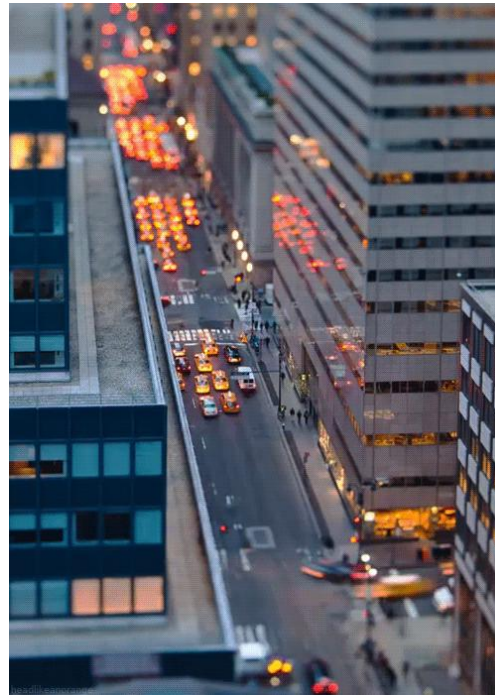

Outline of Module 1

- Lecture 1:
 - True Foundation of AI Systems
- Lecture 2:
 - Input to AI Systems
- Lecture 3:
 - Output from AI Systems

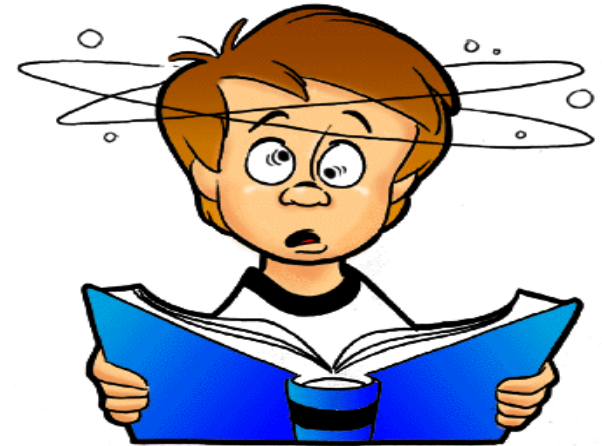

Space
Vector
Time



**NANYANG
TECHNOLOGICAL
UNIVERSITY**

School of Mechanical & Aerospace Engineering

Design, Machine, Control, Intelligence

Lecture 3 of Module 1

AI 3.0

MA4829 Machine Intelligence

Output from AI Systems



XIE Ming, PhD (France)

<http://personal.ntu.edu.sg/mmxie>

“We are living inside an ocean of signals”



What is a system with intelligence inside?

(Learning, Teaching) <o> (Research, Innovation) <o> (Leadership, Service)

Outline of Lecture 3

- Knowledge as Output
- Behaviors as Output
- Discussions



Outline of Lecture 3

- Knowledge as Output
- Behaviors as Output
- Discussions

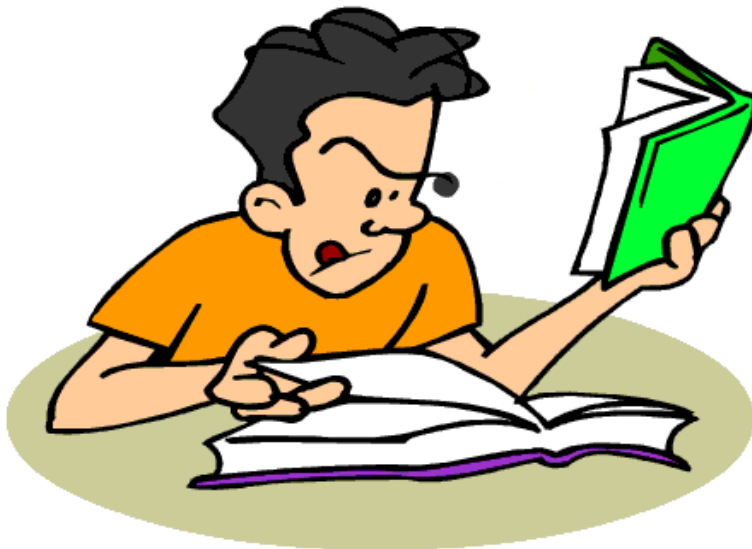

Definition of Conceptual World

- The description of the physical world's knowledge (i.e., properties, constraints and their evolutions) in the form of texts of a human language creates a conceptual world.



Texts in Conceptual Worlds

- The texts in any human language are considered as a conceptual world because they describe the clusters of properties, constraints, behaviors, interactions, events, and episodes in the physical world.
- A text is composed of sentences and questions which are organized into paragraphs, sections, and chapters.
- A text could be translated into equations and programs.

Inside a Mind, There Are Two Major Mental Activities with the Use of Human Languages:

- Understanding of Knowledge
 - From meanings in a conceptual world to meanings in the physical world (visualized inside a mind)
- Description of Knowledge
 - From meanings in the physical world to meanings in a conceptual world



Illustration of Mental Activities of Visual Intelligence Inside a Mind ...

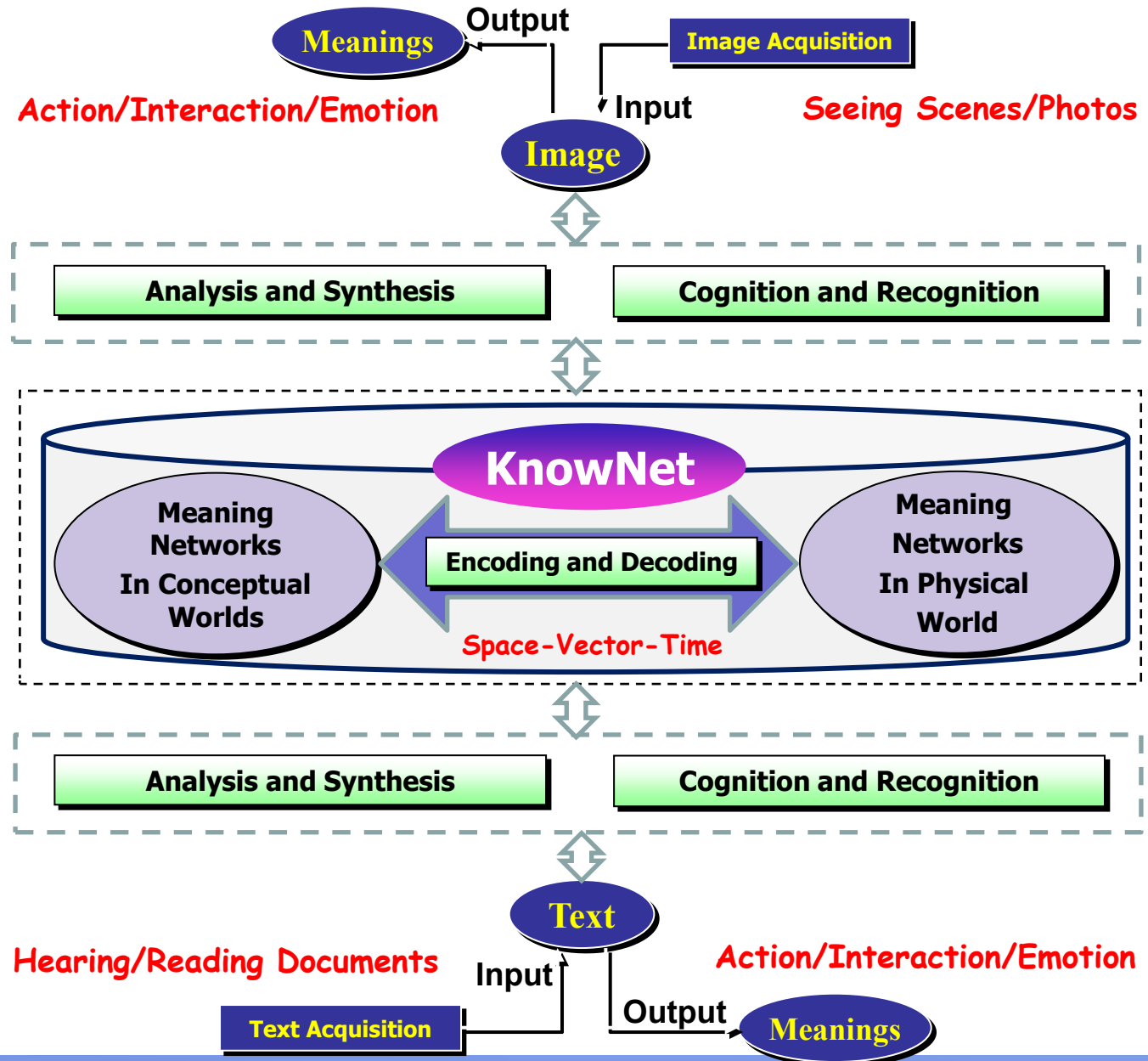

- **Three Mental Dualities:**
Cognition and Recognition
Encoding and Decoding
Analysis and Synthesis

- **Full Scope of AI Pipeline:**
Signal → Knowledge
Knowledge → Knowledge
Knowledge → Signal

What is knowledge understanding?

- It is the mental process of reconstructing the knowledge in the physical world from the texts written in human languages (including illustrations).



Example of Knowledge Understanding

Conceptual World

A robot arm with two links, holds a laser cutting gun. There is a metal sheet which is placed within the workspace of the robot arm. A program is loaded into the robot and guides the robot to cut a shape of dinosaur on the metal sheet. Now, the robot is powered on and it starts the cutting process ... What is the mental imagination inside your mind?

Visualized Meanings inside a Mind

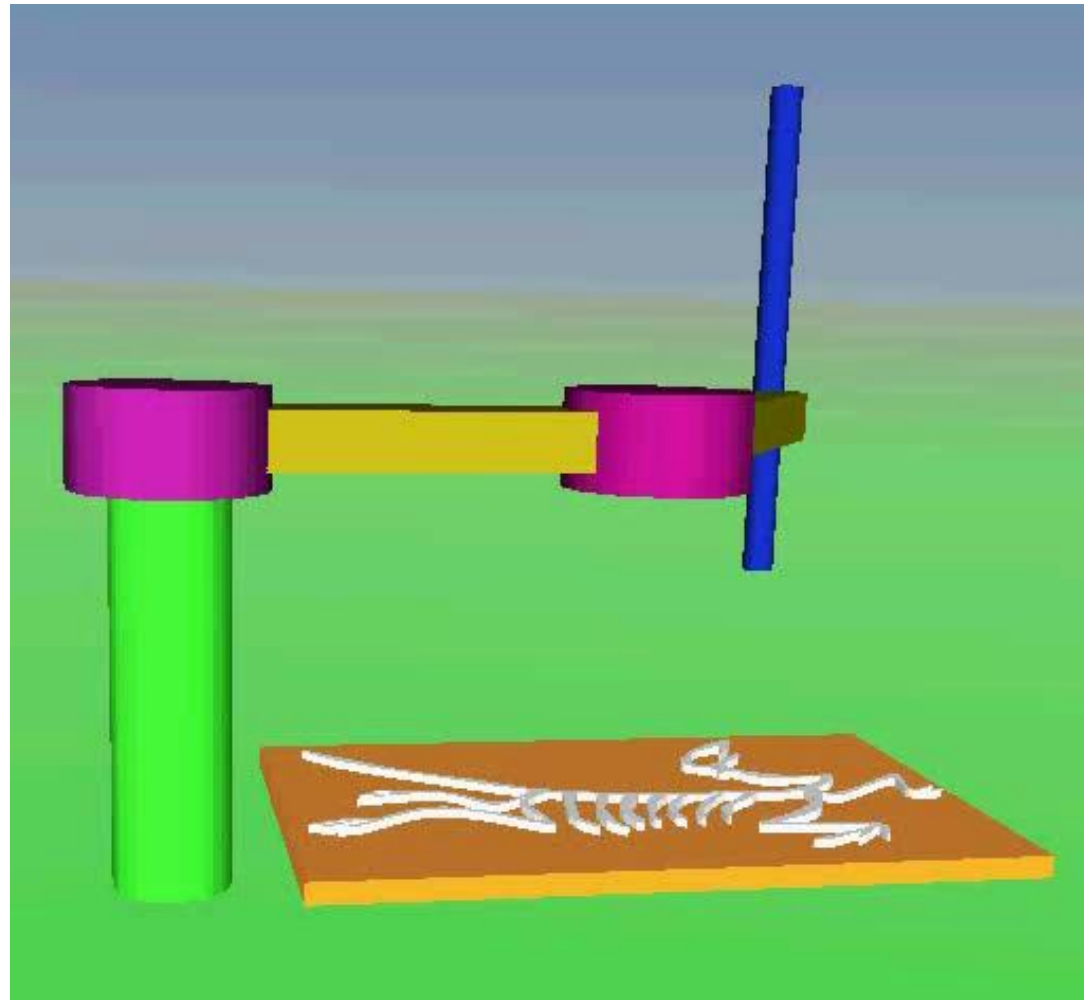

What is knowledge description?

- It is the process of describing the knowledge of the physical world with the texts in human languages.
- A text could be translated into equations and programs.

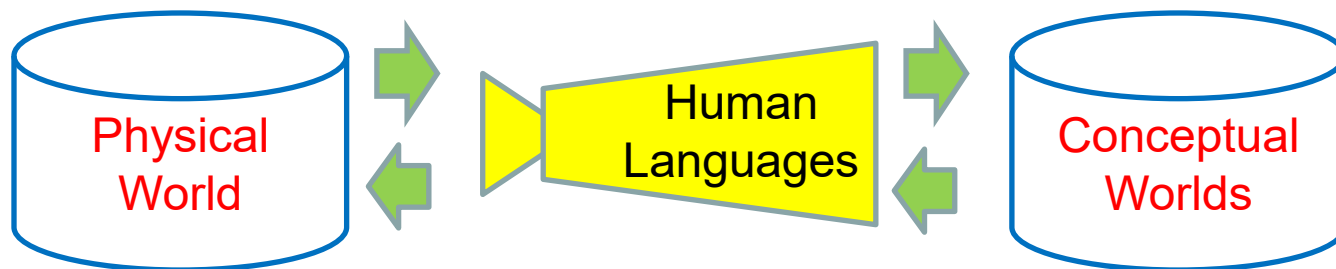

Example of Knowledge Description

- How to describe this dynamic scene?

Physical World



Conceptual World

A car is moving on a road near mountains.



What is the best way to represent knowledge from the physical world?

- The use of human languages which consist of:
 - Natural Languages
 - Technical Language
 - Programming Languages



The use of human languages to represent knowledge creates conceptual worlds!

Outline of Lecture 3

- Knowledge as Output
- Behaviors as Output
- Discussions



AI contributes to the achievement of autonomy by machine ...

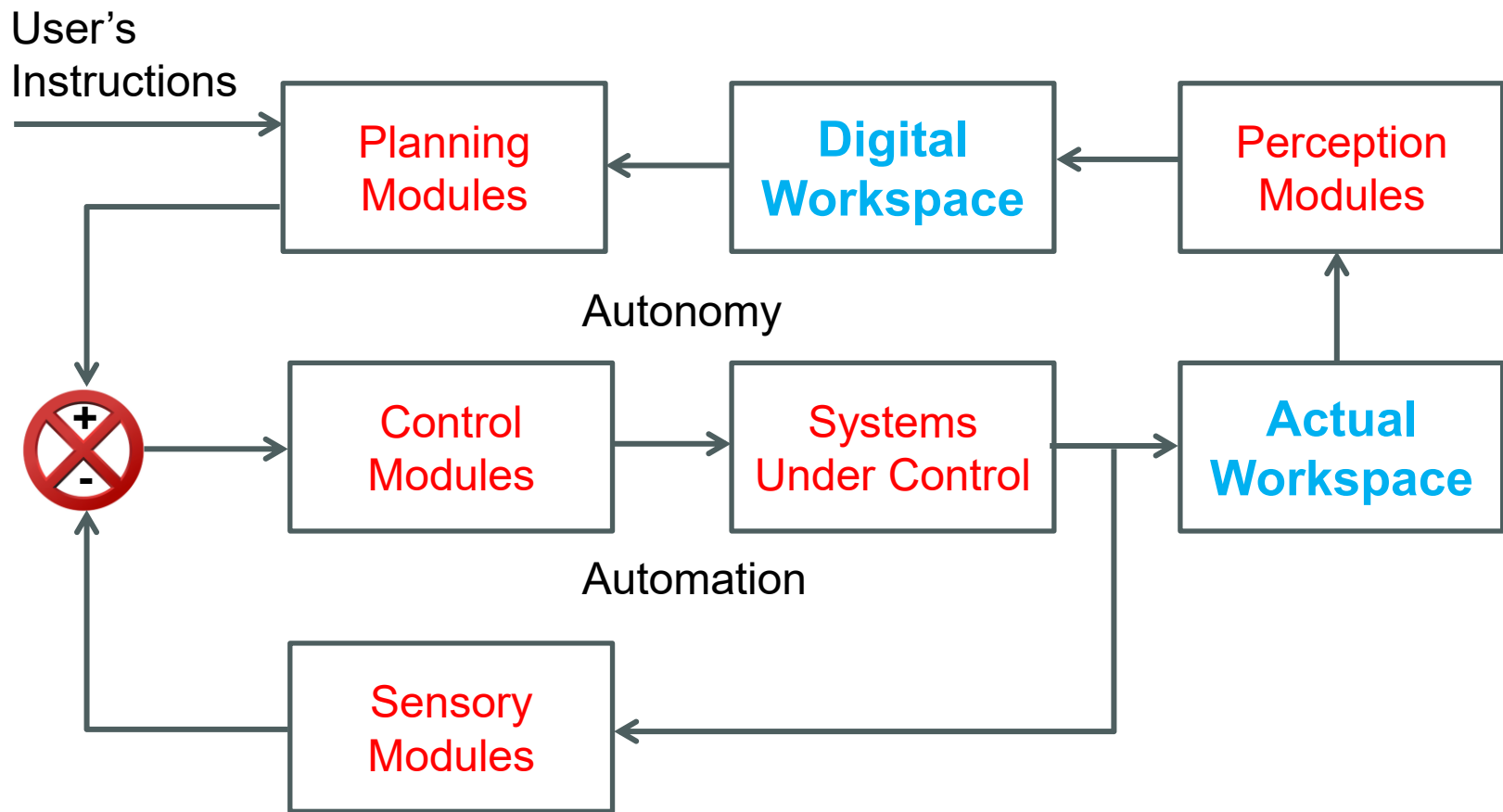

Output from AI systems includes controllable behaviours ...

- Talking
- Seeing
- Reading
- Thinking
- Composing

Task Space

Joint Space

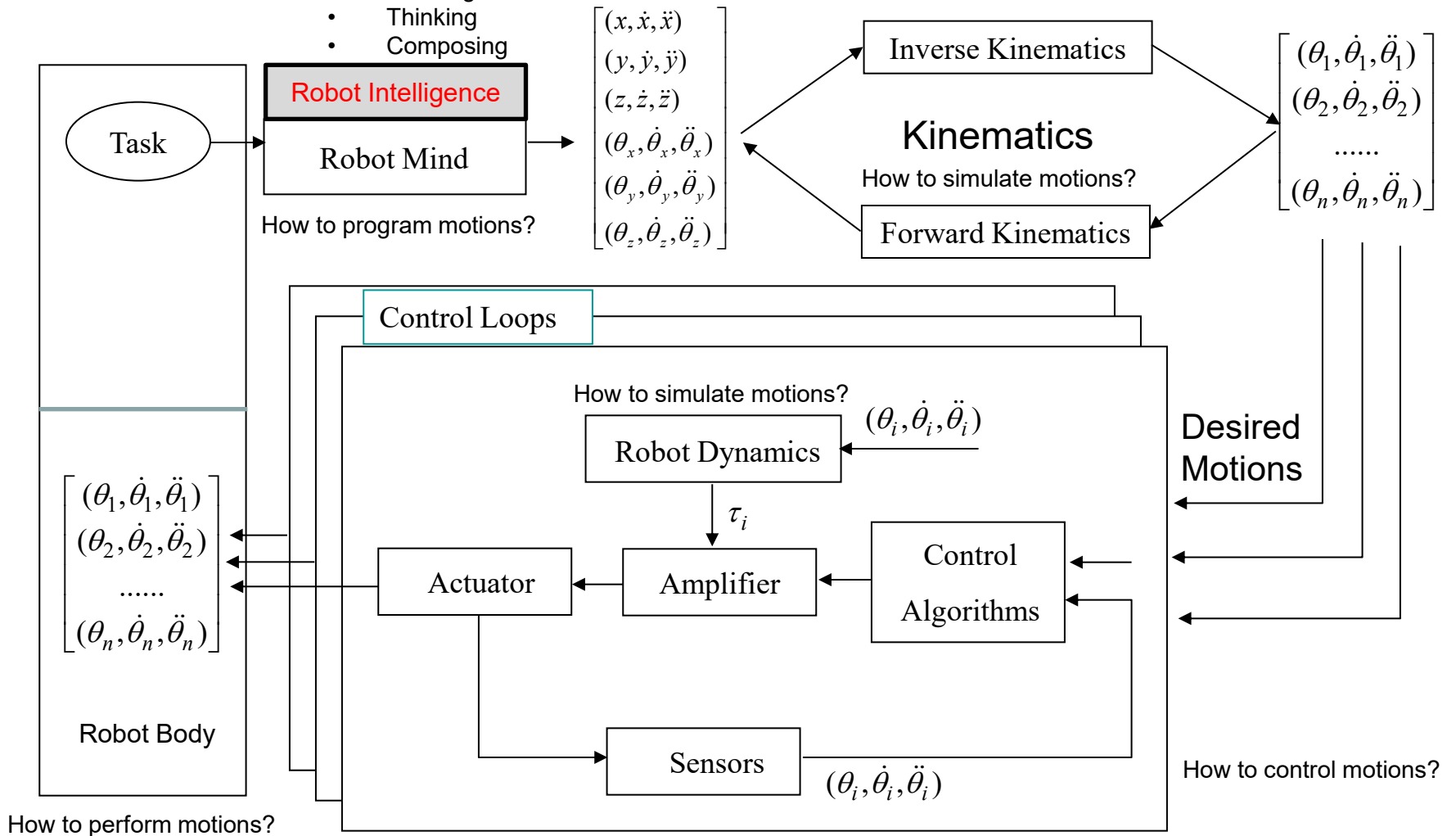

Example of Autonomous Behaviour



Example of Autonomous Behaviour

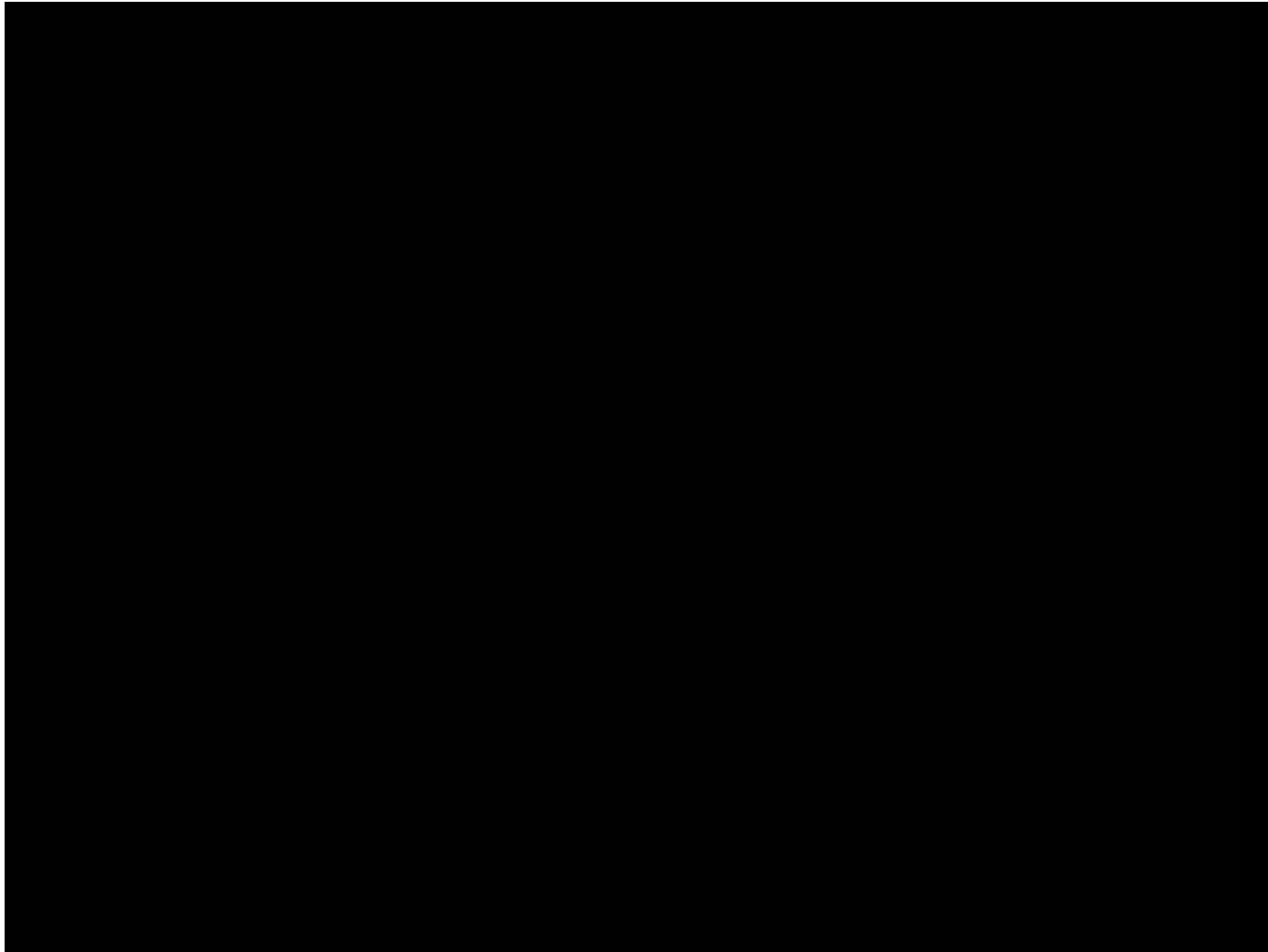

Example of Autonomous Behaviour

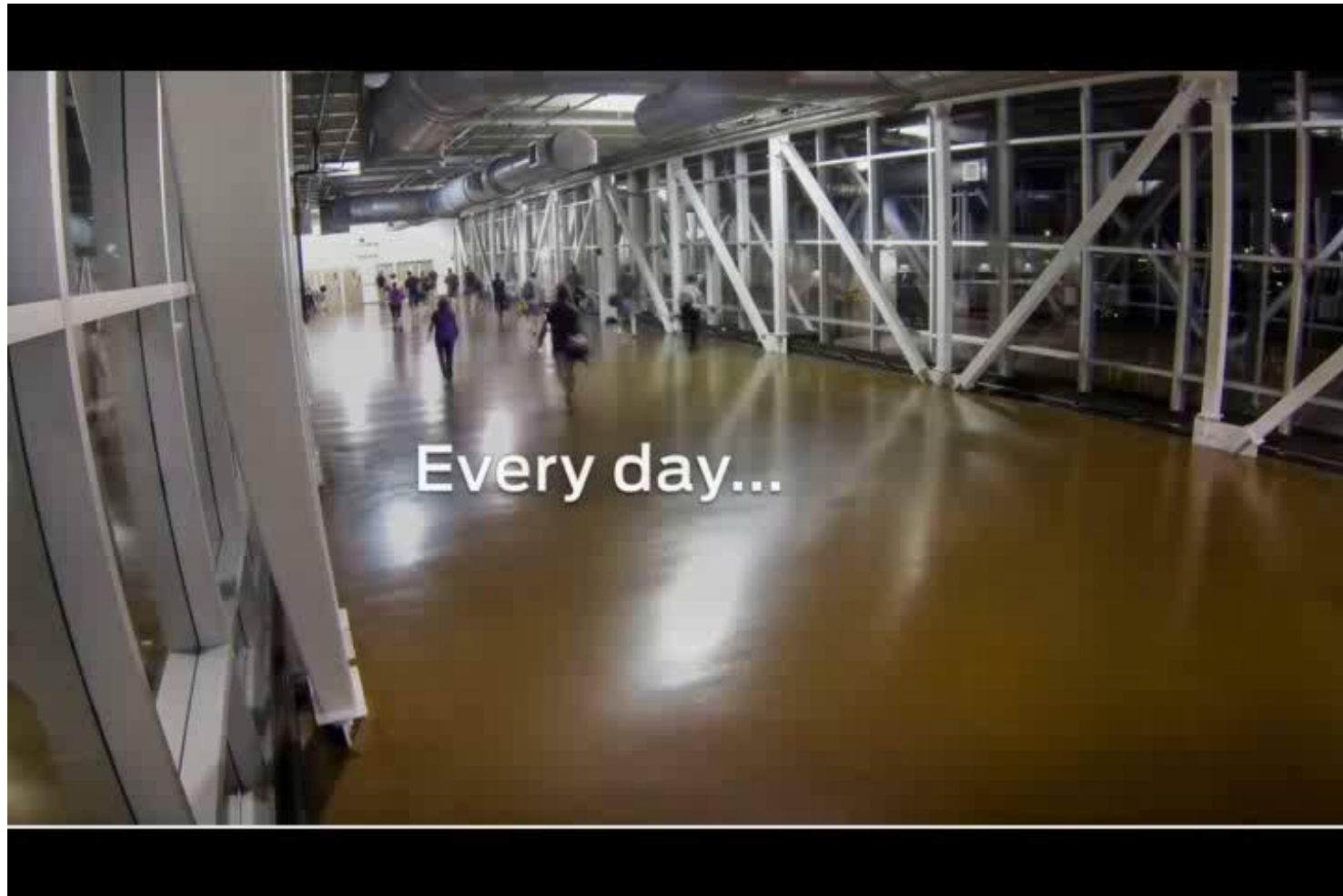

Outline of Lecture 3

- Knowledge as Output
- Behaviors as Output
- Discussions

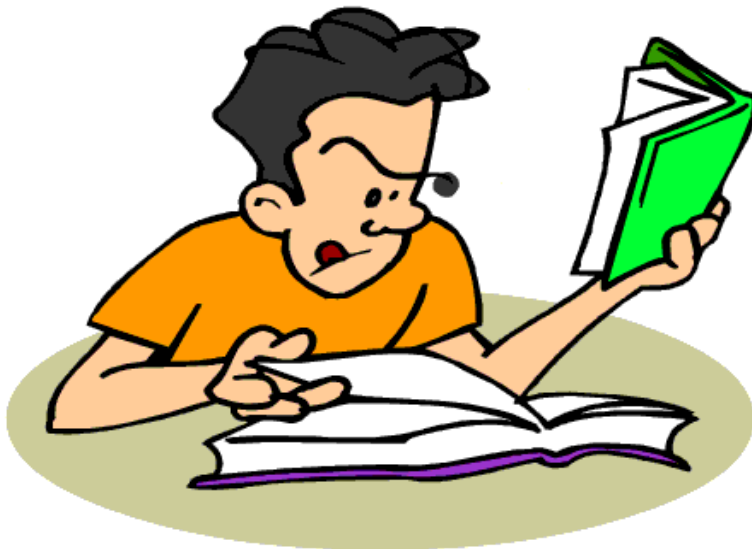

Discussion 1

- What is the common way of representing knowledge?
- It is the use of human languages which include:
 - Natural Languages
 - Technical Languages
 - Programming Languages
- Why?



Discussion 2

- What is a natural language?
- It is a set of words and rules for the purpose of projecting knowledge of the physical world into the texts which form a conceptual world.
- Why?



Discussion 3

- A human being can learn any natural language.

- Is it true?

- Why?

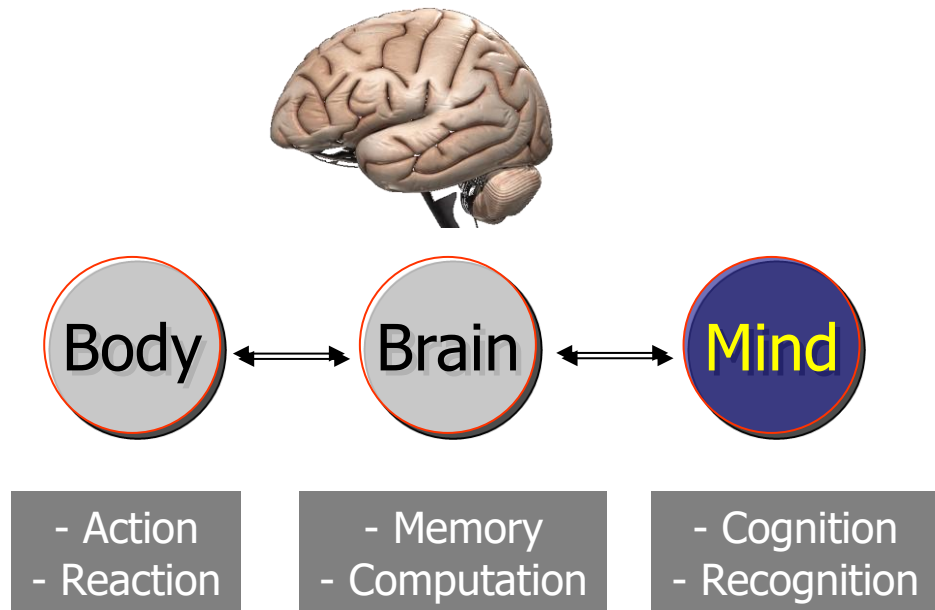

On average, the human brain contains **about 100 billion neurons and many more neuroglia** which serve to support and protect the neurons. Each neuron may be connected to up to 10,000 other neurons, passing signals to each other via as many as 1,000 trillion synapses.

Discussion 4

- An animal, such as dog, cat and others, can never master a natural language regardless of the effort of teaching.

- Is it true?



- Why?

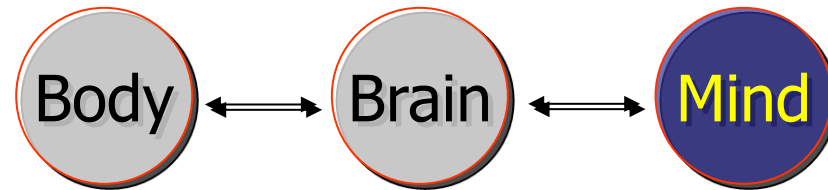

- Action
- Reaction

- Memory
- Computation

- Cognition
- Recognition

On average, the human brain contains **about 100 billion neurons and many more neuroglia** which serve to support and protect the neurons. Each neuron may be connected to up to 10,000 other neurons, passing signals to each other via as many as 1,000 trillion synapses.

Discussion 5

- What is the greatest invention in human history?
- It is human languages.
- Why?

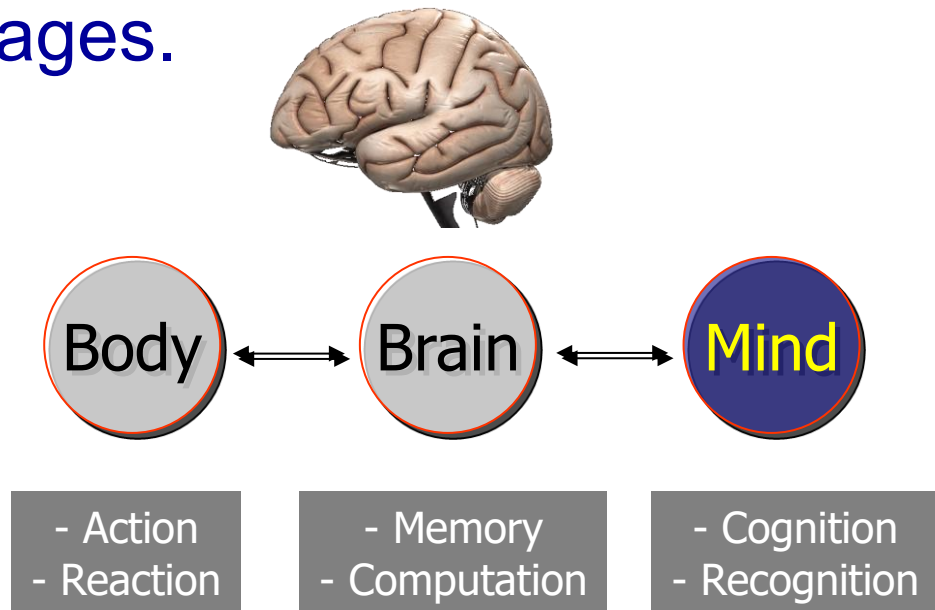

On average, the human brain contains **about 100 billion neurons and many more neuroglia** which serve to support and protect the neurons. Each neuron may be connected to up to 10,000 other neurons, passing signals to each other via as many as 1,000 trillion synapses.

Discussion 6

- Why does a human brain consist of a network of neurons?

• Answer:

- Best **hardware support** for the control of skills
- Best **hardware support** for the cognition and recognition of knowledge

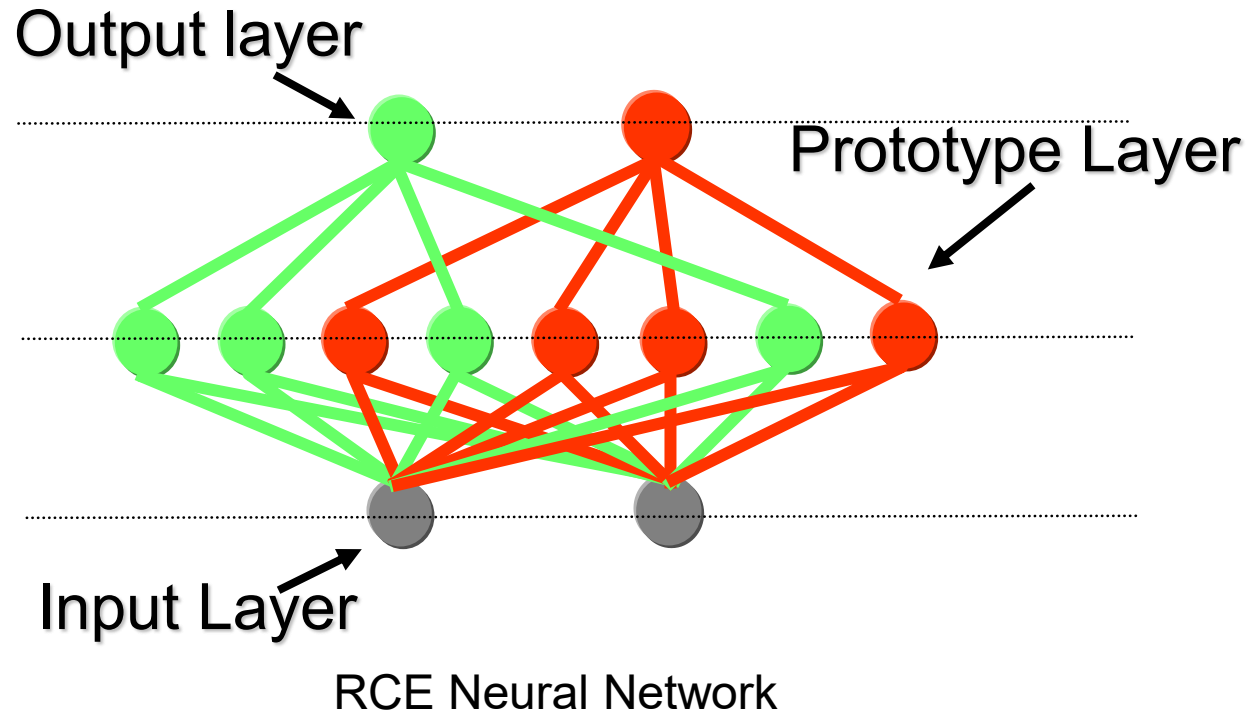

- Prototypes refer to feature vectors of reference features.
- RCE stands for **Restricted Coulomb Energy (RCE)**.
- **RCE-NN is a MIMO system which is equal to the sum of SISOs.**

Discussion 7

- How to achieve incremental cognition or learning?
- Answer: Use of RCE NN!

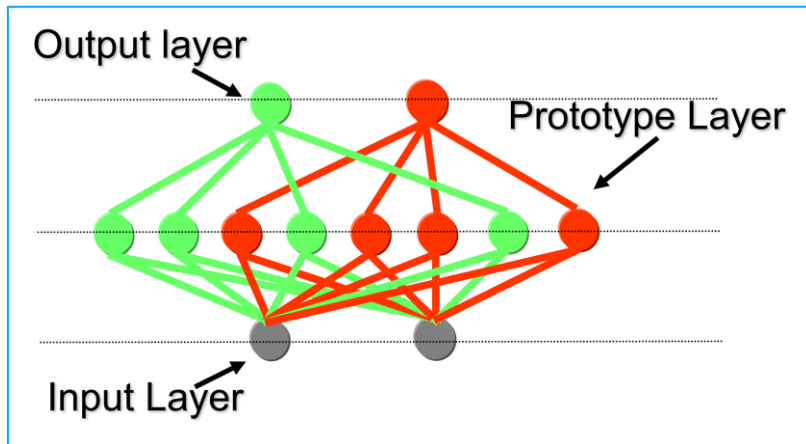

MIMO = Sum of MISOs

MIMO = Sum of SISOs

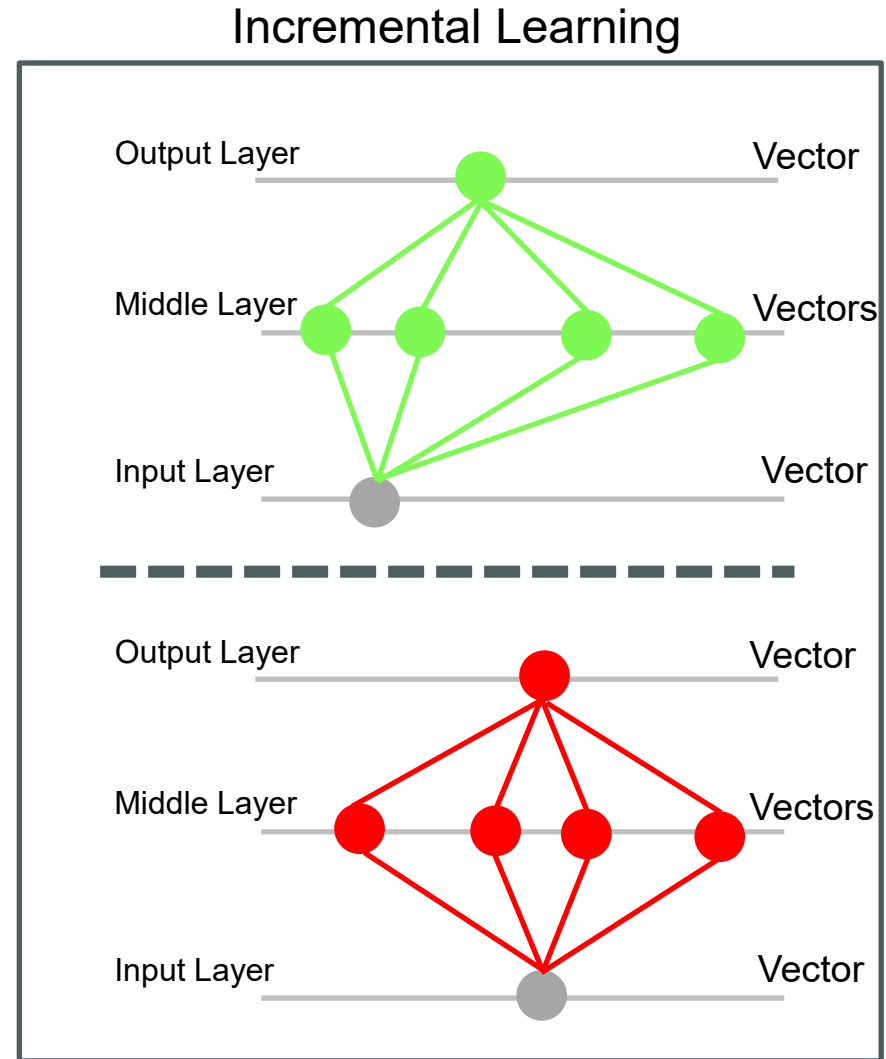

Now, we would like to know ...

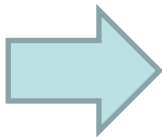
- How to extract meaningful quantities related to visible appearances from digital images?
 - How to describe these meaningful quantities with the use of a human language?
 - The answer will be:
 - Visual Cognition
 - Visual Recognition
-  **Subsequent Modules**

Summary of Lecture 3

- Knowledge as Output
- Behaviors as Output
- Discussions

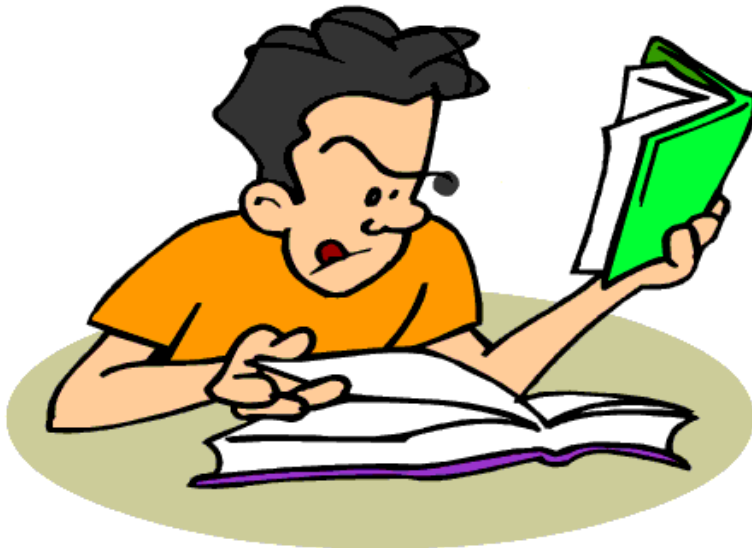

Summary of Module 1

- Lecture 1:
 - True Foundation of AI Systems
- Lecture 2:
 - Input to AI Systems
- Lecture 3:
 - Output from AI Systems





**NANYANG
TECHNOLOGICAL
UNIVERSITY**

School of Mechanical & Aerospace Engineering

Design, Machine, Control, Intelligence

“Ask not what your country can do for you – ask what you can do for your country,” - John F. Kennedy

“Do not think that you are needy – think that you are needed in the world”, - Manis Friedman

“Study will make you knowledgeable, resourceful, and hence more needed”, - Xie Ming

Thank You for Listening!